UDAY SERIES



User Manual

SS-GTI-3P 6kW-A1

SS-GTI-3P 8kW-A1

SS-GTI-3P 10kW-A1

SS-GTI-3P 12kW-A1

Content

1. Introduction	4
1.1 Introduction	4
1.2 Applied designations	4
1.3 Important safety information	5
1.4 System sizing	5
2. Technical description of inverters	6
2.1 Mechanical design	6
2.2 Electrical system design	6
2.3 Technical data	7
2.4 Grid codes	8
3. Installation and startup	10
3.1 Package information	10
3.2 Installation environment	10
3.3 Installation position	11
3.4 Mounting procedure	12
3.5 Electrical connection	13
3.5.1 Earth connection	13
3.5.2 Connection to the grid (AC output)	13
3.5.3 Connection to PV string (DC input)	16
3.6 Communication	16
3.7 RCR Port (Europe Standard)	17
3.8 COM Port	19
3.9 USB Port	19
3.10 Meter connection	19
3.11 RS485 connection	20
3.12 AFCI function (Optional)	21
4. Commissioning	22
4.1 Check before operation	22
4.2 Power on	22
5. User interface	23
5.1 Led and key	23
5.2 LCD operation	24
5.2.1 Setting	26
5.2.2 Language setting	26
5.2.3 Feed in limit setting	26
5.2.4 Date and time setting	27
5.2.5 PV configuration setting	27
5.2.6 Communication address setting	27
5.2.7 Checking error logs	27
5.2.8 System switch setting	27
5.2.9 Inverter information checking	27
5.2.10 Grid code setting	28

5.2.11	DRMO setting	28
5.2.12	AFCI setting	28
5.2.13	PID setting	28
5.2.14	RCR setting	29
5.2.15	Software update	29
5.2.16	New password setting	29
5.2.17	Reset setting	30
5.3	Self-Test in accordance with CEI 0-21 (Applies to Italy only)	30
6.	Warranty	30
6.1	Warranty claim procedure	30
6.2	Service after warranty expiration	31
7.	Troubleshooting	31
8.	Maintenance	33
8.1	Routine Maintenance	33

Notice

This manual contains important safety instructions, as well as information on installation, electrical connections, commissioning, maintenance, and troubleshooting of the equipment.

Save the manual!

This manual must be stored carefully and be available at all times.

1. Introduction

1.1 Introduction

This manual describes solar inverters:









SS-GTI-3P 6kW-A1/ SS-GTI-3P 8kW-A1/ SS-GTI-3P 10kW-A1/ SS-GTI-3P 12kW-A1.

These inverters are transformerless.

Please read the safety instructions in this manual carefully before use. Throughout the manual, it is assumed that the reader is familiar with AC and DC installations and knows the rules and regulations for electrical equipment and connecting it to the utility AC grid. It is especially important to be familiar with the general safety rules for working with electrical equipment.

1.2 Applied designations

Throughout the manual, important information is shown at different levels depending on the character of the information, as shown here:

	<p>Safety information is important for human safety. Violation of warnings may result in injury to persons or death.</p>
	<p>Danger of high voltage and electric shock!</p>
	<p>Signals danger due to electrical shock and indicates the time (5 minutes to allow after the inverter has been turned off and disconnected to ensure safety in any installation operation.</p>
	<p>Danger of hot surface!</p>
	<p>The product should not be disposed of as normal household waste.</p>
	<p>CE Mark</p>
	<p>ROHS Mark</p>
	<p>Information important for the protection of property. Violation of this type of information may cause damage and loss of property.</p>
	<p>Useful additional information or "Tips and Tricks" on specific subjects.</p>

1.3 Important safety information

Read this before installing, operating, or maintaining the inverter.

Before installation:

Check for damage to the inverter and packaging. If you are in doubt, please contact your supplier before installing the inverter. Check the voltages of the solar modules and make sure they are within the limits of the inverter specifications before connecting them to the inverter.

Installation:

Only trained and authorized personnel familiar with local electrical codes may install the inverter. For optimum safety, please follow the steps described in this manual. Keep in mind that the inverter has two voltage-carrying sides, the PV input and the AC grid.

Disconnecting the inverter:

Always disconnect the AC line first! Afterwards, disconnect the PV lines. Note that the inverter can still be charged with very high voltages at hazardous levels even when it is disconnected from the grid and solar modules. Wait at least 5 min. Before proceeding, after having disconnected from the grid and PV panels.

Operating the inverter:

Before connecting the AC grid to the inverter, make sure that the installation cover is mounted again. The inverter must not be opened during operation.

Maintenance and modification:

Only authorized personnel are allowed to repair or modify the inverter. To ensure optimum safety for the user and the environment, only the original spare parts available from your supplier should be used.

Functional safety parameters:

Unauthorized changes of functional safety parameters may cause injury or accidents to people or the inverter. Additionally, it will lead to the cancellation of all inverter operating approval certificates.



1.4 System sizing



When dimensioning a photovoltaic system, it must be ensured that the open circuit voltage of the PV string never exceeds the maximum permissible input voltage of 1100 VDC. The PV string open circuit voltage during parallel string operation is 1000V. Higher voltages may result in permanent damage to the inverter.

The selection of PV string output should be based on the optimum utilization of the invested capital compared to the expected annual energy yield from the system. This optimization depends on local weather conditions and should be considered in each individual case.

The inverter incorporates an input power limiting device, which automatically keeps the power at levels that are safe for the inverter. The limitation depends mainly on internal and ambient temperatures. The limitation is calculated continuously and always allows the maximum possible amount of energy to be produced.

Please use the tool supplied by the manufacturer when dimensioning a photovoltaic system.

2. Technical description of inverters

2.1 Mechanical design

Figure 2-1 shows the outline dimensions of SS-GTI-3P 6kW-A1/ SS-GTI-3P 8kW-A1/ SS-GTI-3P 10kW-A1/ SS-GTI-3P 12kW-A1.

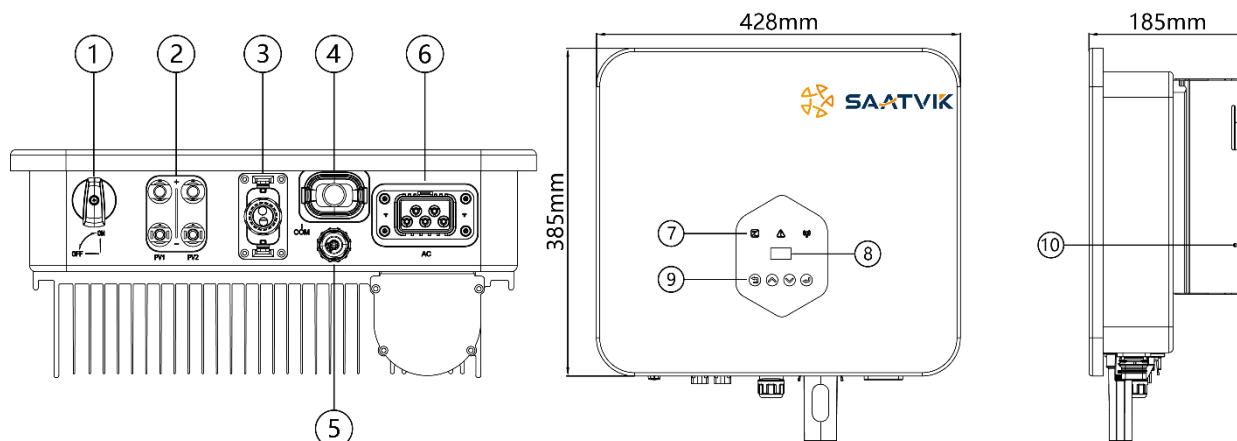

Figure 2-1 Outline dimensions

No.	Description	No.	Description
1	DC Switch	2	DC (PV terminals)
3	I/O port	4	Communication port
5	RCR port (Europe Standard)	6	AC terminal
7	LED (Run / Fault / Communication)	8	LCD
9	Key	10	Ground terminal



For safety reasons, the use of a DC switch is recommended. Between the PV modules and the power modules may be mandatory in some countries.

2.2 Electrical system design

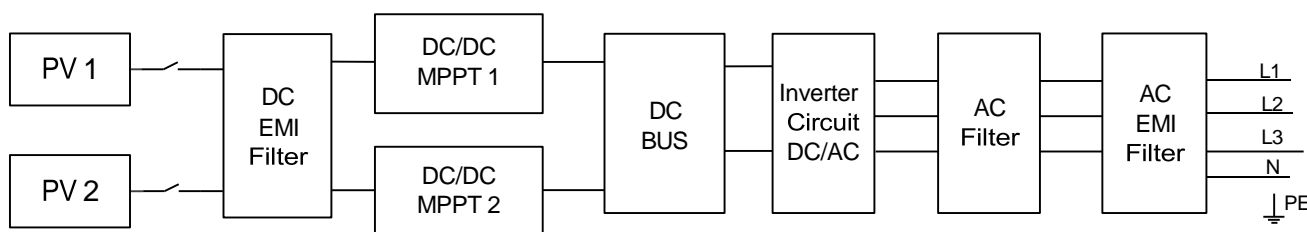

Figure 2-2 Block diagram of the inverter system

2.3 Technical data

Model	SS-GTI-3P 6kW-A1	SS-GTI-3P 8kW-A1	SS-GTI-3P 10kW-A1	SS-GTI-3P 12kW-A1
DC Input				
Max. Recommended PV Power [Wp]	9000	12000	15000	18000
Max. PV Power for Single MPPT [Wp]	4500	6000	7500	9000
Max. PV Input Voltage [V]	1100			
MPPT voltage Range [V]	140 ~ 1000			
Start-up Voltage [V]	160			
No. of MPP Trackers	2			
No. of Input Strings per Tracker	1 / 1			
Max. PV Input Current [A]	16 / 16			
Max. Short-circuit Current per MPPT [A]	20 / 20			
Max. Back feed Current to Array [A]	0			
AC Output				
Rated AC Output Power [W]	6000	8000	10000	12000
Max. AC Output Apparent Power [VA]	6600	8800	11000	13200
Rated AC Voltage / Range [V]	3 / N / PE, 220 / 380, 230 / 400; ±20%			
Grid Frequency / Range [Hz]	50 / 60; ±5			
Max. Continuous Current [A]	10	13.4	16.7	20
Max. Output Fault Current (Peak and Duration)[A]	45 (1ms)			
Inrush Current (Peak and Duration)[A]	3 (20ms)			
Maximum Output Overcurrent Protection [A]	61			
Adjustable Power Factor [cos φ]	0.8leading ~ 0.8lagging			
Output THDi (@Rated Output)	< 3%			
Efficiency				
Max. Efficiency	98.4%	98.5%	98.5%	98.5%
Euro Efficiency	97.5%	98.0%	98.0%	98.0%
Protection				
DC Switch	Integrated			
DC Insulation Monitoring	Integrated			
Input Reverse Polarity Protection	Integrated			
Anti-island Protection	Integrated			
Residual Current Monitoring	Integrated			
AC Overcurrent Protection	Integrated			
AC Short-circuit Protection	Integrated			
Arc fault circuit interrupter (AFCI)	Optional			
Potential induced degradation (PID) recovery function	Optional			
DC Surge Protection	Integrated (Type II)			

Model	SS-GTI-3P 6kW-A1	SS-GTI-3P 8kW-A1	SS-GTI-3P 10kW-A1	SS-GTI-3P 12kW-A1
AC Surge Protection	Integrated (Type II)			
General Data				
Size(Width*Height*Depth) [mm]	428*385*185			
Weight [kg]	15			
Display	LED + OLED			
Communication	RS-485 and USB(Standard), Wifi or 4G or Ethernet (Optional)			
Ambient Temperature Range [°C]	-25 ~ 60			
Relative Humidity	0 ~ 100%			
Operating Altitude [m]	≤ 2000			
Standby Self Consumption	< 1W			
Topology	Transformerless			
Cooling	Natural Convection			
Enclosure	IP65			
Pollution Degree	III			
Overvoltage Category	DC II / AC III			
Protective Class	I			
Certifications & Standards				
Grid Regulation	NB/T 32004, ORDINANCE No.140, EN50549-1, EN50549-PL, IEC61727 / IEC62116			
Safety Regulation	EN 62919-1, EN 62619-2			
EMC	EN IEC 61000-6-1, EN IEC 61000-6-2, EN IEC 61000-6-3, EN IEC 61000-6-4			



2.4 Grid codes

No.	National/Regional Grid Code	Description
0	VDE4105-DE	Germany's power Grid meets Grid standards "VDE-AR-N-4105".
1	CEI0-21	Italy's power Grid.
2	Australia A	Australia: A power Grid.
3	RD1699	Spain's power Grid.
4	EN50549	Default EN50549 Grid setting.
5	EN50549-DK-W	West Denmark Power Grid.
6	Greece	Greek Power Grid.
7	EN50549-NL	Netherlands Power Grid.
8	C10/11	Belgium Power Grid.
9	G99	UK Power Grid.
10	China	China Power Grid, meet Grid standards "CN-NBT".
11	VDE0126-FR	France's power Grid meets Grid standards "VDE 0126".
12	EN50549-PL	Poland's power Grid.
13	Brazil-180s	Brazil power Grid, connect/reconnect time 180s.
14	VDE0126-DE	Germany's power Grid meets the Grid standards "VDE 0126".
15	CEI0-16	Italy's power Grid meets the Grid standards "CEI0-16".
16	G98	UK Power Grid.

No.	National/Regional Grid Code	Description
17	Greece Island	Greece Island Power Grid.
18	EN50549-CZ	Czech Republic Power Grid.
19	IEC61727-IN	India Power Grid.
20	Korea	Korea Power Grid.
21	EN50549-SW	Sweden's power Grid.
22	China-W	China Power Grid, Grid voltage range: 160-264.5V. Grid frequency range: 47-52Hz.
23	China-H	China Power Grid. Grid voltage range: 160-280V.
24	IEC61727-IN-W	India Power Grid. Grid voltage range: 195.5-280V.
25	Brazil	Brazil power Grid, meet Grid standards "NBT 16150".
26	IEC61727-SL	Sri Lanka Power Grid, meet Grid standards "IEC61727".
27	Mexico	Mexico power Grid, meet Grid standards "IEC61727 60Hz".
28	New Zealand	New Zealand Power Grid.
29	Philippines	Philippines power Grid, meet Grid standards "IEC61727 60Hz".
30	IEC61727-SL-W	Sri Lanka Power Grid, Grid voltage range: 160-280V. Grid frequency range: 47-52Hz.
31	PEA	Thailand's power Grid.
32	PEA-W	Thailand's power Grid. Grid voltage range: 160-280V. Grid frequency range: 47-52Hz.
33	IEC61627-VN	Vietnam Power Grid.
34	IEC61627-VN-W	Vietnam Power Grid. Grid voltage range: 160-280V. Grid frequency range: 47-52Hz.
35	Tunisia	Tunisia.
36	MEA	Thailand's power Grid.
37	MEA-W	Thailand's power Grid. Grid voltage range: 160-280V. Grid frequency range: 47-52Hz.
38	Brazil-LV	120V 60Hz voltage of grid L to N (SS - GTI - 3P-10-15K-LV only, others reserved).
39	EN50549-DK-E	East Denmark Power Grid.
40	Tunisia-W	Tunisia wide range. Grid voltage range: 160-290V.
41	Chile	Chile Power Grid.
42	Brazil-W	Brazil's power Grid. Grid voltage range: 160-290V.
43	EN50549-PL-W	Poland's power Grid. Grid voltage range: 160-290V.
44	Brazil-180s-W	Brazil's power Grid. Grid voltage range: 160-290V.
45	UNE217002-ES	Spain power Grid.
46	G98-NI	G98 for Northern Ireland.
47	G99-NI	G99 for Northern Ireland.
48	EN50549-NW	Norway-400VLine
49	EN50549-NW-LV	Norway-230VLine-SS - GTI - 3P-10-15K-LV only, others reserved.
50	IEC61727-LV	133V 50Hz, low-voltage power grid.
51	EN50549-IR*/	Ireland power Grid.
52	Austria	Austria's power Grid.
53	Australia B	Australia B power Grid.

No.	National/Regional Grid Code	Description
54	Australia C	Australia C power Grid.
55	EN50549-SIST	Slovenia Grid.
56	EN50549-HUN	Hungary Grid.
57	Pakistan	Pakistan Grid.

3. Installation and startup

	<p>WARNING!</p> <p>Before installation and maintenance, the AC and DC sides don't carry electricity, but if the DC side is just disconnected, the capacitance still contains electricity, so please wait for at least 5 minutes to ensure the capacitors completely release the energy and the inverter is not electrified.</p>
	<p>NOTE!</p> <p>Inverters must be installed by a qualified person.</p>

3.1 Package information

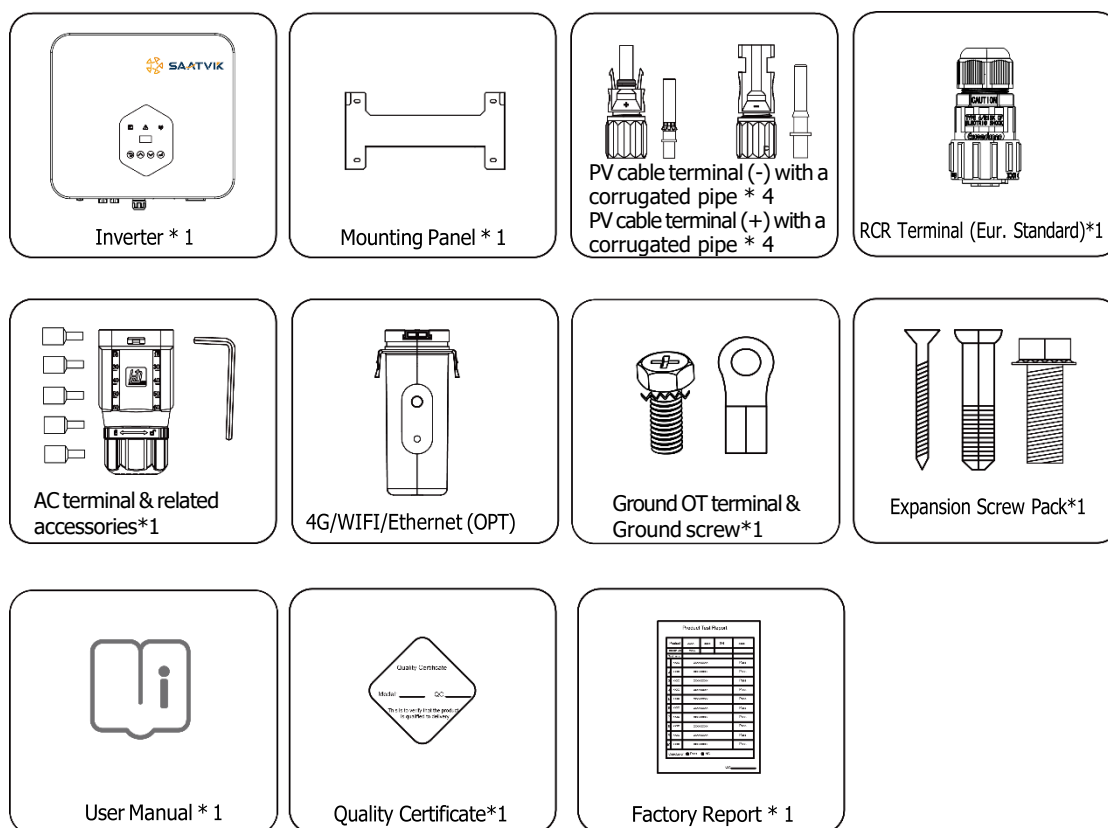

Figure 3-1 Package information

3.2 Installation environment

- 1) To achieve optimal performance, the ambient temperature should be kept lower than 45 °C.
- 2) For the convenience of checking the LCD and possible maintenance activities, please install the inverter at eye level.
- 3) Inverters should NOT be installed near inflammable or explosive items. Any strong electromagnetic equipment should be kept away from the installation site.

- 4) The product label and warning symbol shall be clear to read after installation.
- 5) Please do not install the inverter under direct sunlight, rain, or snow.

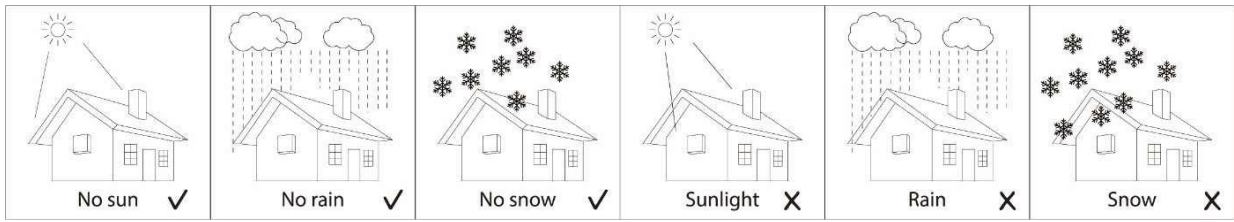

Figure 3-2 Installation environment

3.3 Installation position

	<ol style="list-style-type: none"> 1) The installation method and mounting location must be suitable for the inverter's weight and dimensions. 2) Mount on a solid surface. 3) Select a well-ventilated place sheltered from direct sun radiation.
--	---

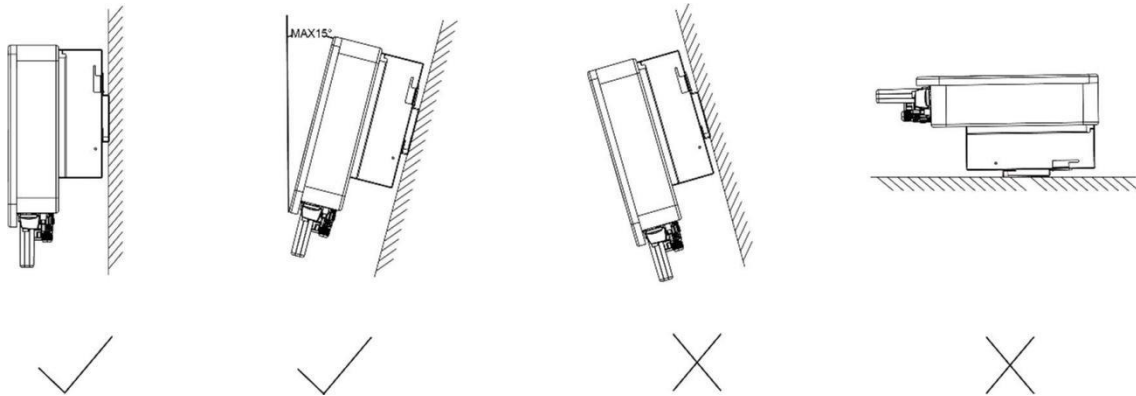

Figure 3-3 Installation position

In consideration of heat dissipation and convenient dismantlement, the minimum clearances around the inverter should be no less than the following value.

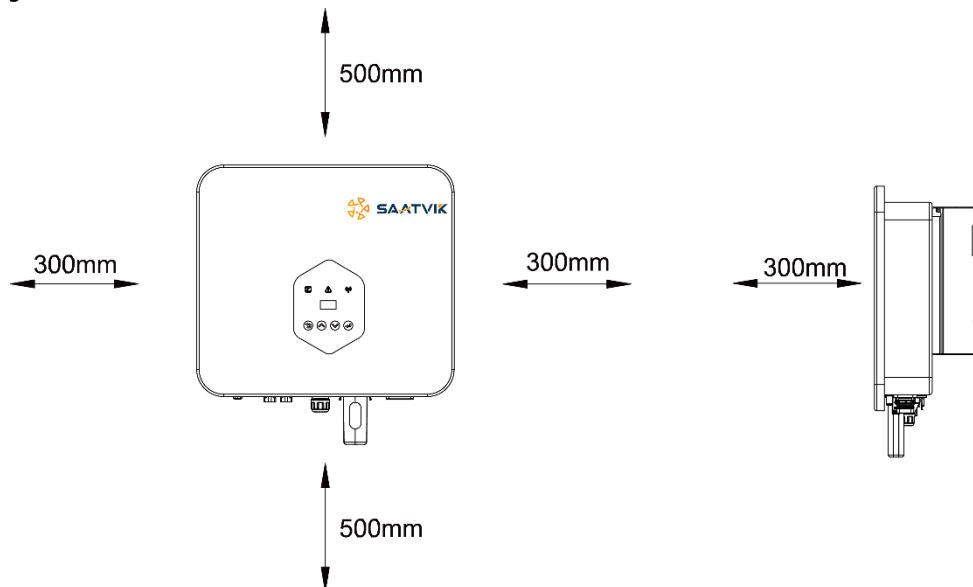

Figure 3-4 Installation space

3.4 Mounting procedure

1. Drill 4 Fix ϕ 11 holes in the wall according to the dimensions.

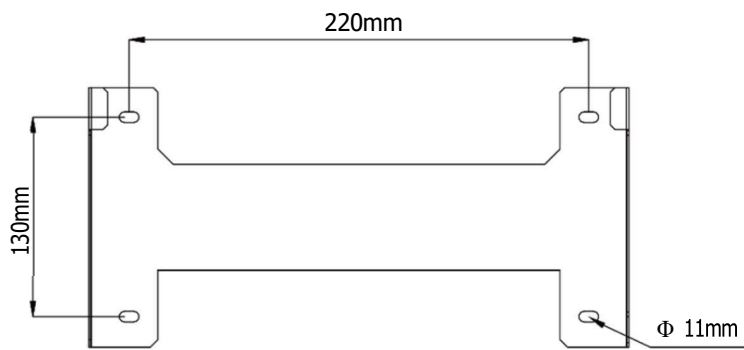

Figure 3-5

2. Fix the wall mounting bracket on the wall with 4 expansion bolts in the accessory bag.

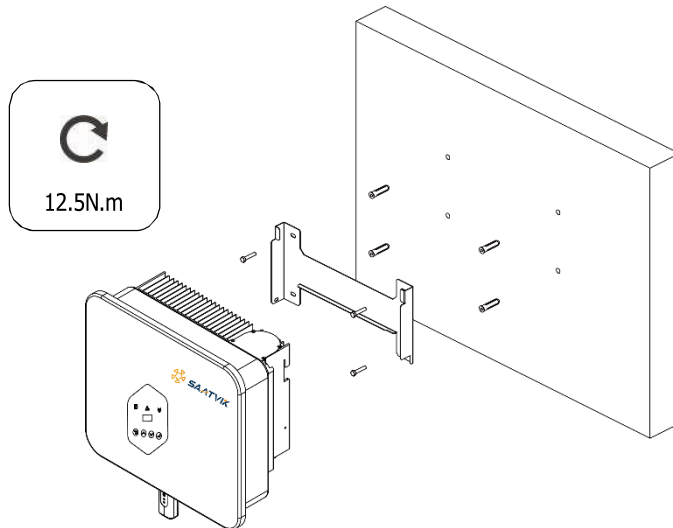

Figure 3-6

3. Place the inverter on the wall-mounted bracket and install the fix screw.

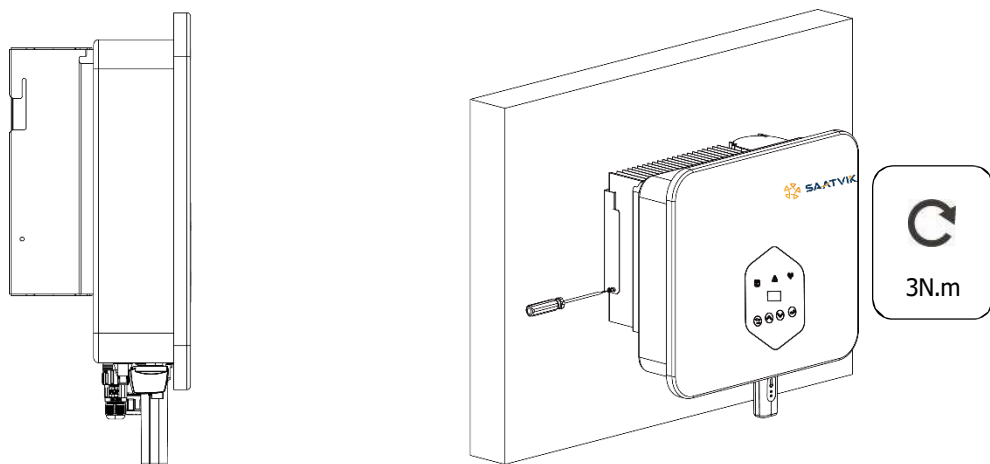

Figure 3-7 Mounting the inverter

3.5 Electrical connection

3.5.1 Earth connection

One can additionally earth the inverter enclosure of a second earthed or equipotential bonding, which is required under local regulations. This prevents touch current if the original protective conductor fails.

Cable size: 4mm²

Connection steps:

Strip the earthed cable insulation.

Insert the stripped cable into the ring terminal.

Clamp the end of the ring terminal.

Unscrew the screw of the earthed connector.

Insert the ring terminal on the earthed connector.

Fix the gasket on the earthed connector.

Tighten the screw of the earthed connector.

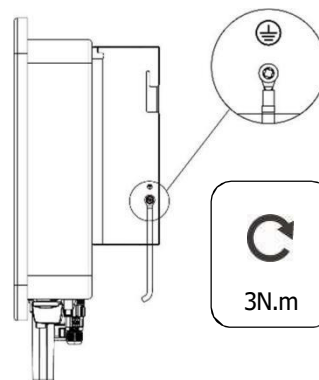

Figure 3-8

3.5.2 Connection to the grid (AC output)



- 1) Add breaker or fuse to AC side, the specification should be more than 1.25 times of rated AC output current.
- 2) The PE line of inverter should be connected to the earth, make sure the impedance of neutral wire and earth wire less than 10 ohm.
- 3) Disconnect the breaker or fuse between the inverter and the utility.
- 4) All inverters incorporate a certified internal Residual Current Device (RCD) in order to protect against possible electrocution and fire hazard in case of a malfunction in the PV array, cables or inverter. There are 2 trip thresholds for the RCD as required for certification (IEC 62109-2:2011). The default value for electrocution protection is 30mA, and for slow rising current is 300mA.

Connect the inverter to the grid as follows:

1. Strip off L1 / L2 / L3 / N / PE.

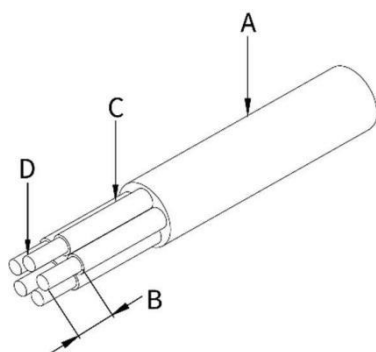

Figure 3-9 Strip off N / L1 / L2 / L3 cables

No.	Description	Remark
A	Protective layer	Diameter ranges : 15-24mm
B	Length of stripped off	6mm
C	Insulate layer	50mm
D	Cross section of ac cables	6-10mm ²

2. Crimp the terminals with crimping pliers and set the parts on the cable.

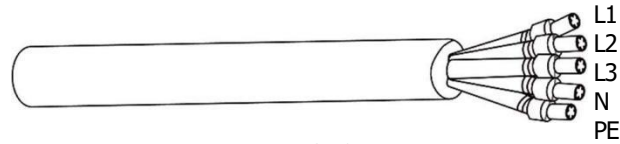

Figure 3-10

3. Fully insert the conductors to the corresponding terminal and tighten the screws with a torque $2.0 \pm 0.1\text{N}\cdot\text{m}$. Pull cables outward to check whether they are firmly installed.

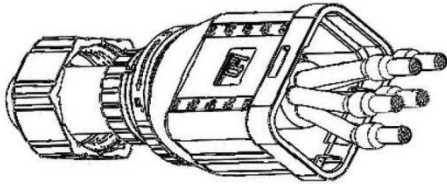

Figure 3-11

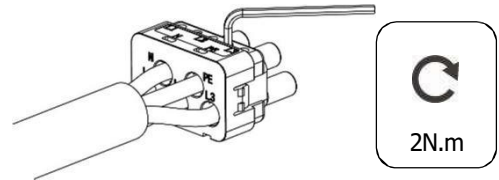

Figure 3-12

4. Assemble the housing, the terminal block, and cable gland. Make sure that the rib of the terminal block and the groove on the housing engage perfectly until a "Click" is heard or felt.

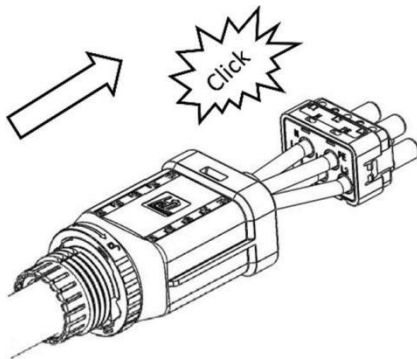

Figure 3-13

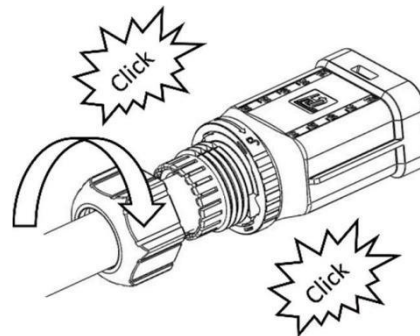

Figure 3-14

5. Insert the main part of AC terminal into the terminal and hear a "Click" sound. Complete the installation.

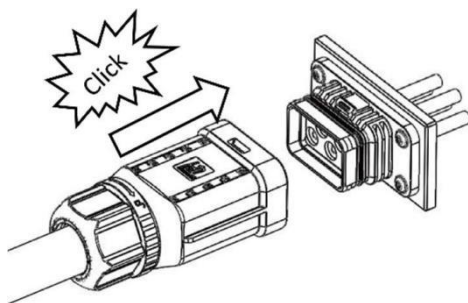

Figure 3-15

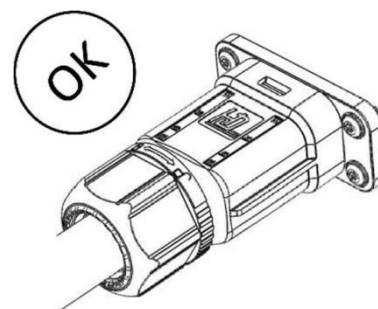

Figure 3-16

Disassemble the inverter from the Grid:

1. Use a screwdriver to press against the unlocked position and hold the wire nut, and pull it back to complete the separation of the male and female ends.

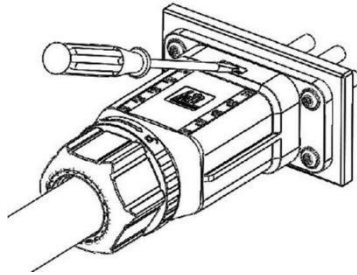

Figure 3-17

2. Pull the female end back against the unlocked position to separate it from the inverter end.

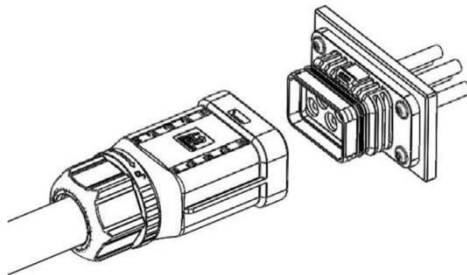

Figure 3-18

3. Hold the unlocking buckle with one hand and rotate it in the direction of the mark, and turn the nut in the opposite direction.

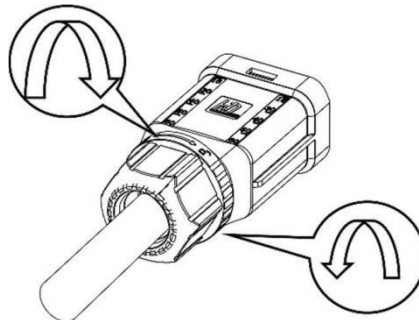

Figure 3-19

4. Use a screwdriver to peel back the red circle locations on both sides to complete removal.

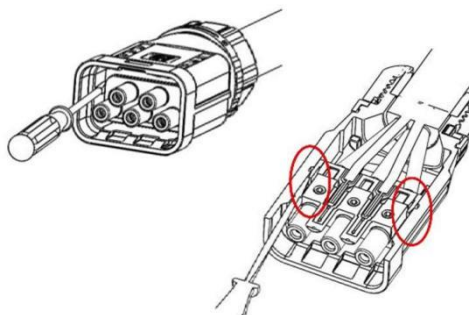

Figure 3-20

3.5.3 Connection to PV string (DC input)



- 1) Before connecting PV string, make sure DC switch is turned off.
- 2) Make sure PV string polarity confirms with DC connector, otherwise, it will cause damage to inverter.
- 3) Make sure the maximum open circuit voltage (Voc) of each PV string does not exceed the inverter input voltage Vmax under any condition.
- 4) Do not connect positive or negative pole of PV string to earth wire. Otherwise, it will cause damage to inverter.

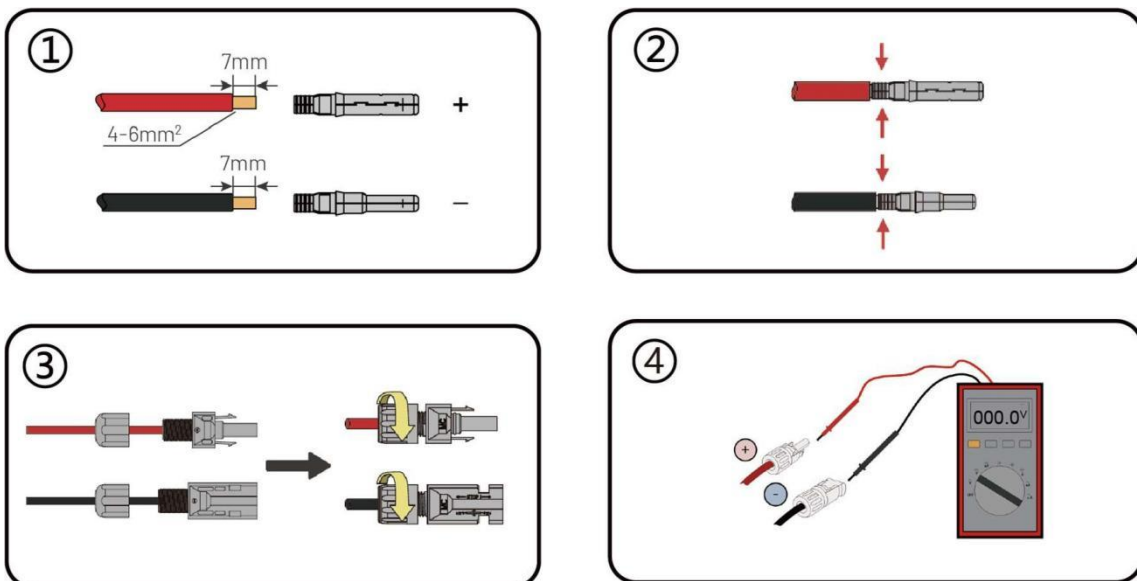
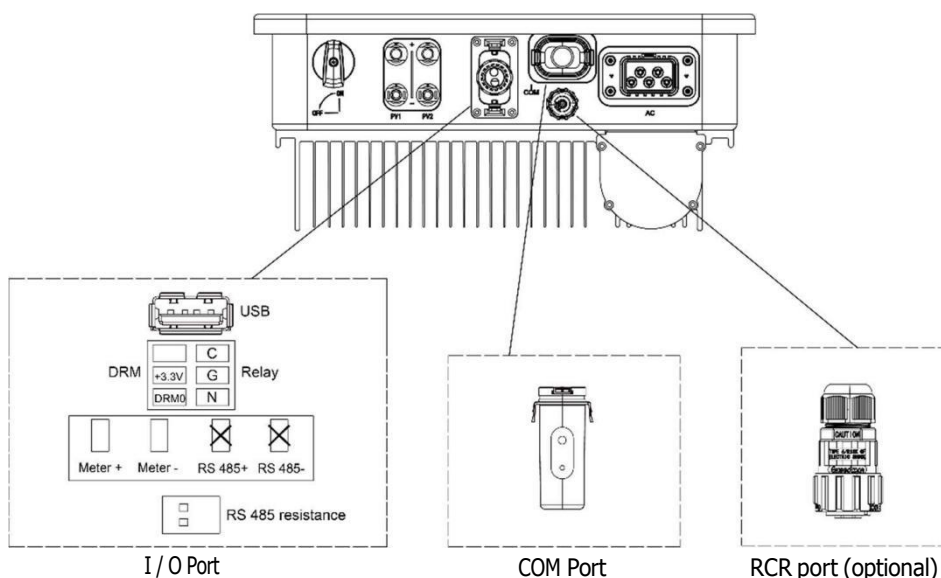

Figure 3-21 PV connection

3.6 Communication



Note: The RS-485 resistance does not need to be changed.

Figure 3-22 Communication connection

3.7 RCR Port (Europe Standard)

In Europe, the grid company uses the Ripple Control Receiver (RCR) to convert the grid dispatching signal and send it as a dry contact signal. The wiring of the ripple control receiver dry contact cables is shown in the figure below.

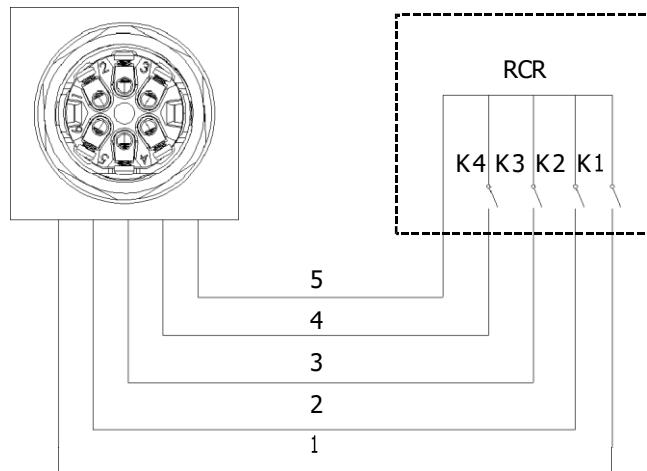

Figure 3-23

K1	K2	K3	K4	Switch Operation on External RCR	Output power (in % of the rated AC output power)
1	0	0	0	Close K1	100%
0	1	0	0	Close K2	60%
0	0	1	0	Close K3	30%
0	0	0	1	Close K4	0%

Connect to the RCR port:

1. Strip five cables, and the diameter of the stripped cables cannot exceed 3mm.
2. Crimp the five cables.

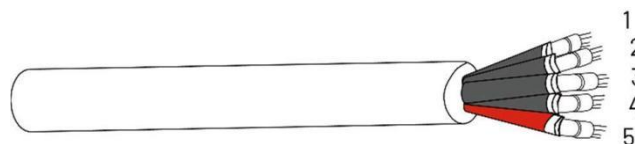

Figure 3-24

3. Pass the crimped wire into the RCR connector.

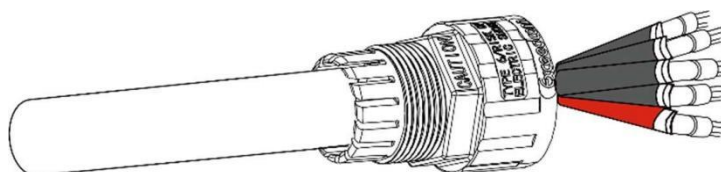

Figure 3-25

4. The cables are inserted into the terminal according to the wire sequence (K1/K2/K3/K4/+3.3V), so that the insulating terminal is flush with the surface of the terminal, and the crimping screw torque is 0.2N·m.

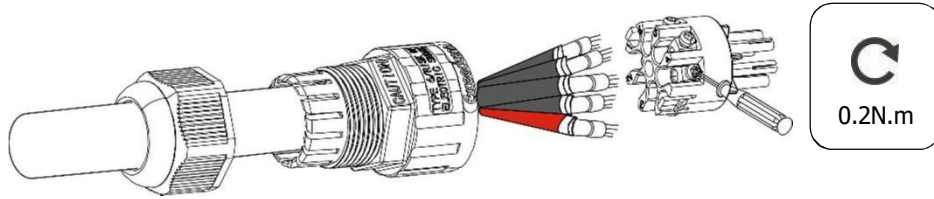

Figure 3-26

5. Insert the terminal block into the male head, and there is a "click" sound.

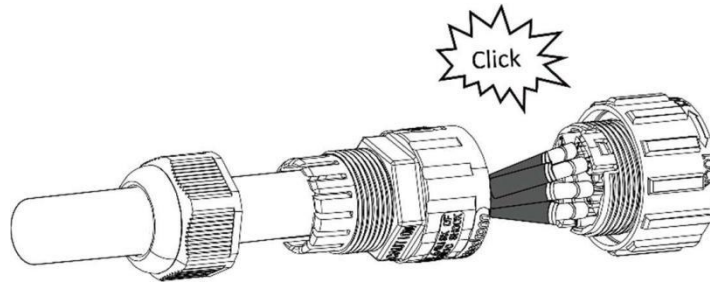

Figure 3-27

6. Use a wrench to tighten the nut.

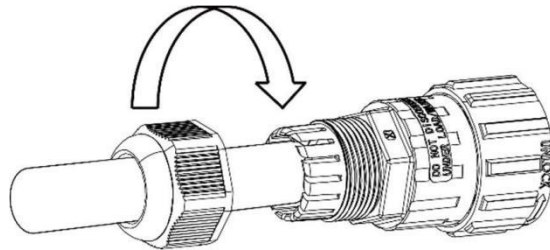

Figure 3-28

7. Screw the male head into the female and complete the installation.

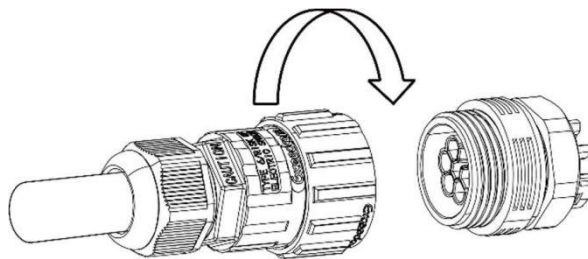

Figure 3-29

3.8 COM Port

Connect the WIFI / 4G / Ethernet module to the COM port of the inverter. After the connection is successful, you can view the inverter's power generation, operation status, and other information through the mobile phone app. Please refer to the user manual of WIFI / 4G / Ethernet module for details.

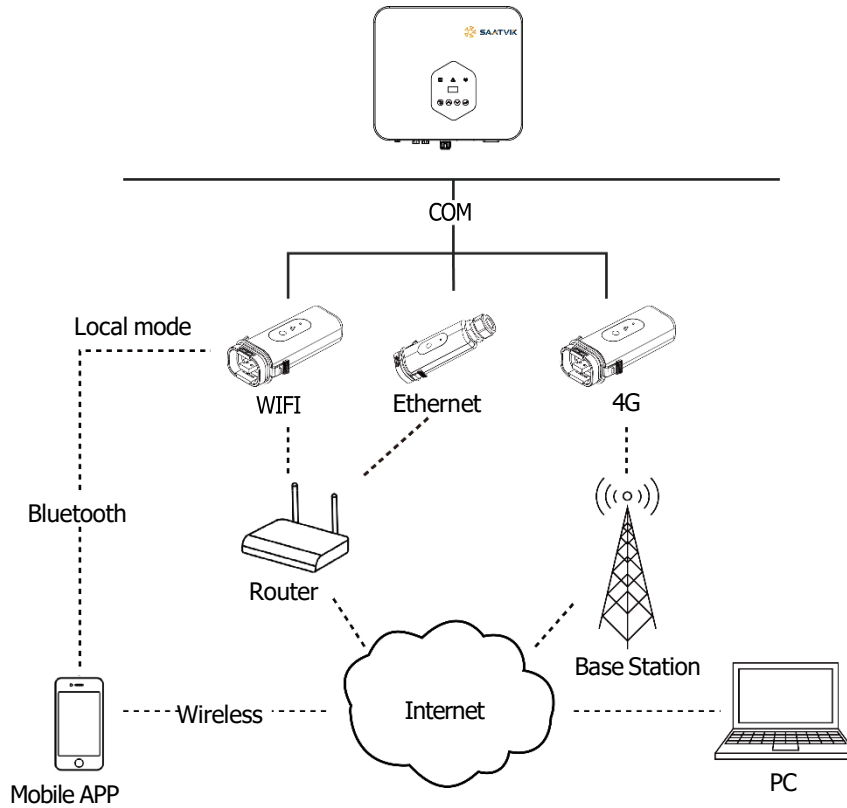

Figure 3-30

3.9 USB Port

Insert a USB flash disk for local software upgrade. Please contact after-sales personnel for details.

3.10 Meter connection

The SS - GTI - 3P 6-12kW series inverter has the function of anti-reverse current, which can control the power exported to the grid by connecting an intelligent electricity meter.

Note: The arrow on the CT must point to the load.

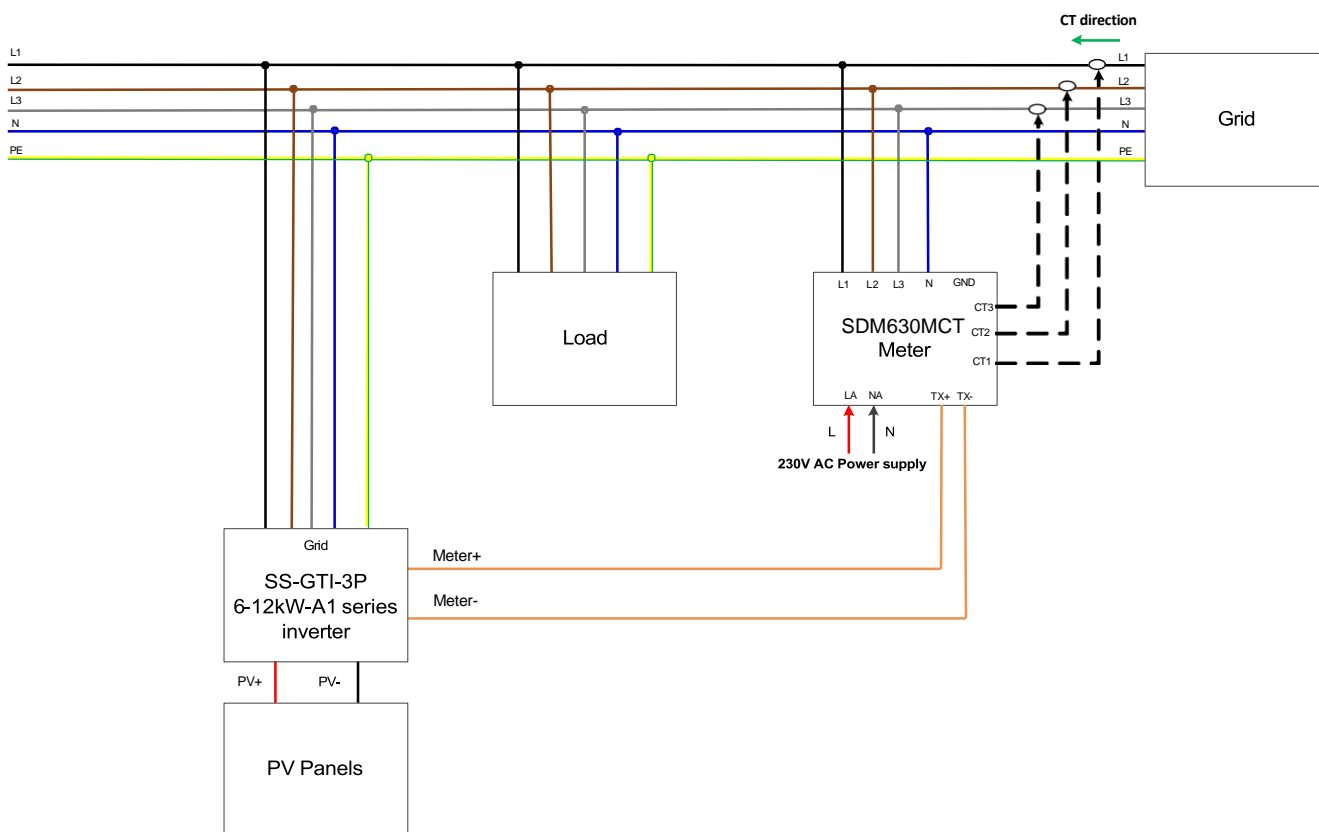

Figure 3-31



The meter communication port needs to be connected correctly, otherwise it will not be able to communicate.

3.11 RS485 connection

(1) Single inverter communication system:

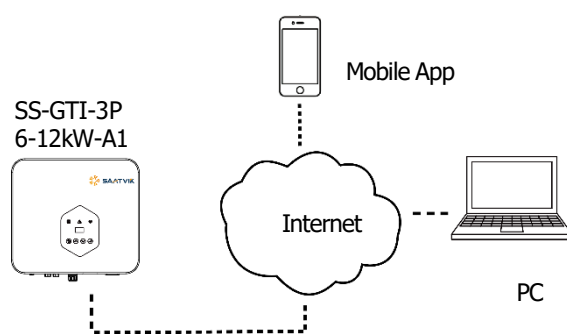

Figure 3-32

The SS-GTI-3P 6-12kW-A1 series inverter can upload data to the Mobile App and cloud platform through the collection module. Please refer to the ST-WIF-G2 User Manual in detail.

(2) Multi-inverter communication system:

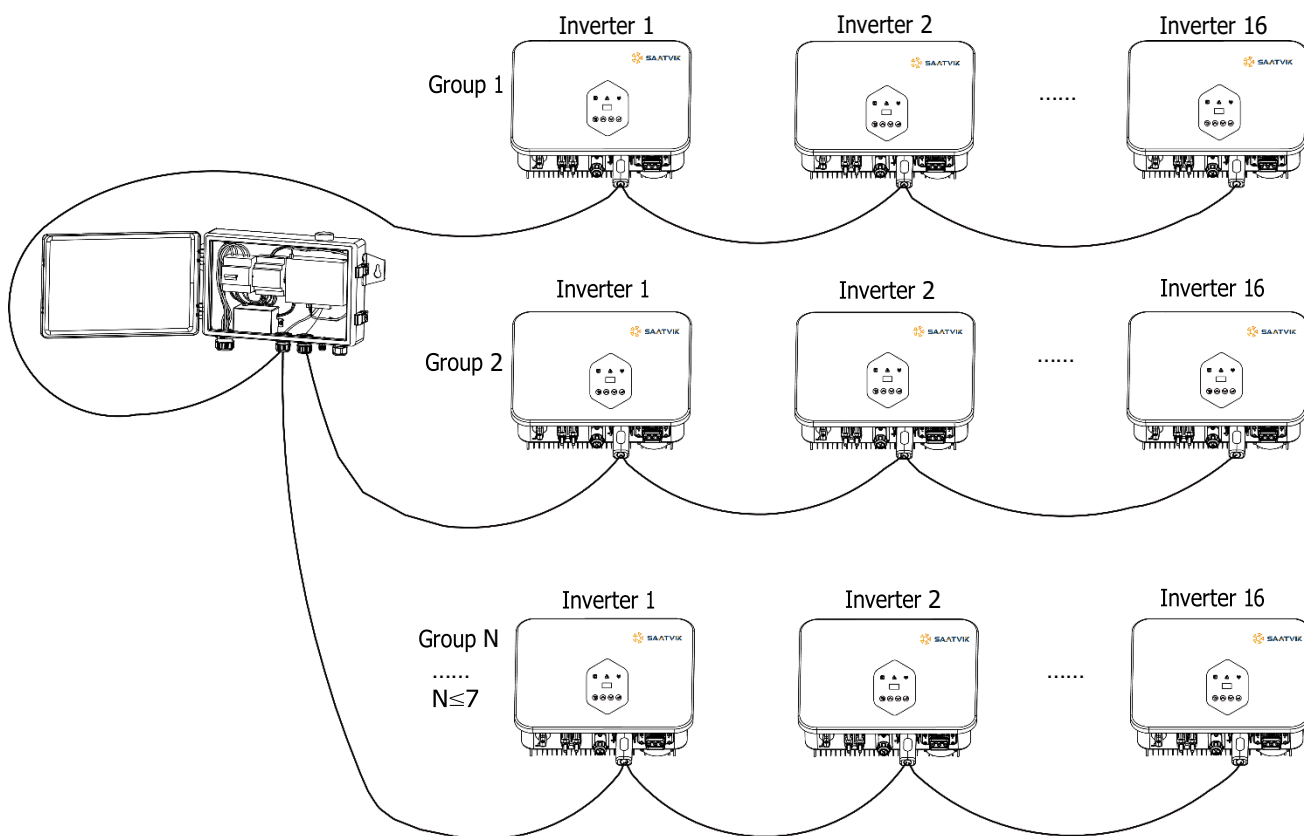

Figure 3-33

In a large power plant, the EMB-100 (Optional) enables the networking of 112 inverters, and it has a monitoring and export limit function. The EMB-100 (Optional) and the tools for connecting the inverters need to be purchased separately. See the EMB-100 User Manual for details.

3.12 AFCI function (Optional)

The AFCI function involves the DC arc fault alarm.

The inverter has an automatic clearance mechanism for the AFCI alarm. If an alarm is triggered less than five times within 24 hours, the inverter automatically clears the alarm. If the alarm is triggered five times or more within 24 hours, you need to manually clear the alarm on the inverter so that it can work properly. See section 5.2.12 AFCI setting for details.

AFPEs and AFDs may be designed in many different ways. The following table defines the classification rules.

Protection coverage	Method of implementation	Functionality	Monitored strings	Input ports	Monitored channels
1. Full coverage (F)	1. Integrated (I)	1. AFPE	Number of strings	Number of input ports	Number of monitored channels
2. Partial coverage (P)	2. Stand-alone (S)	2. AFD			
	3. Distributed (D)				

Following the table, the SS - GTI - 3P 6-12kW-A1 series inverter can be characterized by F-I-AFPE-1-1-2, which means an integrated AFPE providing full coverage for 1 monitored string with 1 input port and 2 monitored channels.

4. Commissioning

4.1 Check before operation

- 1) Three phases of five wires (PE/L1/L2/L3/N) cable correctly connected to the inverter AC side through the AC circuit breaker;
- 2) The DC cable is connected correctly to the inverter DC side through the DC circuit breaker. Please pay attention to the cable connected to the string correctly and its polarity.
- 3) The unused terminals are covered.

4.2 Power on

- 1) Close the DC and AC circuit breakers.
- 2) If the PV panels provide enough energy, the power module will work, and the LCD panel will be lit.
- 3) If you are starting the inverter for the first time, the inverter needs to be commissioned. For example, language, time, etc.
- 4) Then the inverter will turn into self-check mode, and the LCD panel will display the remaining time of connection simultaneously.
- 5) After the inverter turns into normal mode, it feeds electrical energy into the grid, and the LCD panel will display the generated electrical energy.

As long as the inverter works, it will automatically track the maximum power point to absorb the maximum energy from the solar. When night comes, the irradiance is not strong enough to provide energy, and the inverter will power off automatically. When the next day comes, the input voltage reaches the start value, and it will start again automatically.

5. User interface

5.1 Led and key

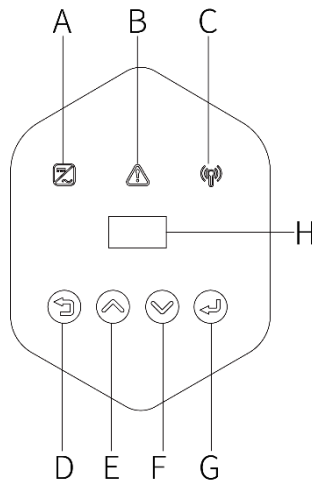
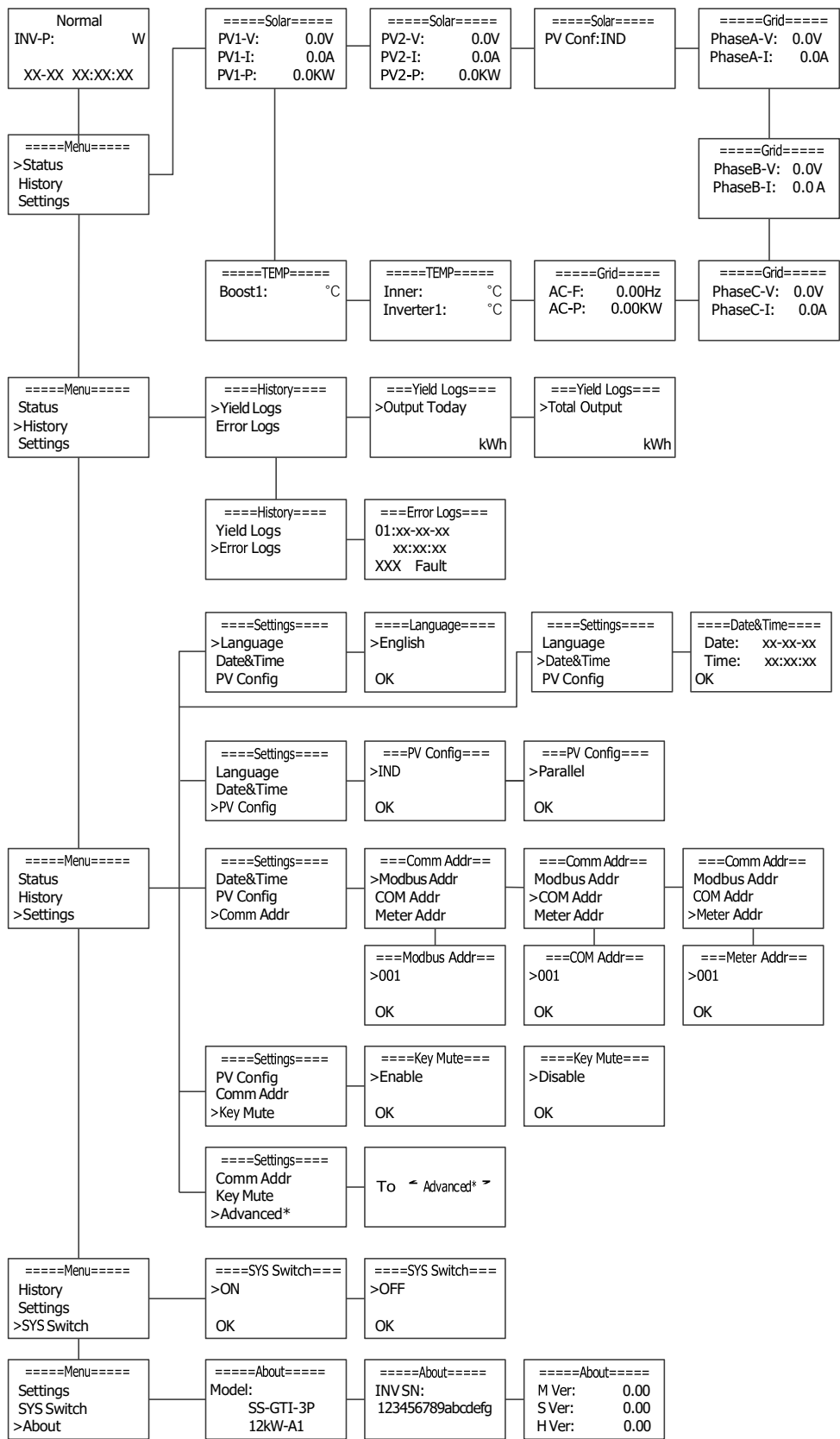

Figure 5-1 LED display

No.	Name	Description	
A	Green indicator	On	The inverter is connected to the grid and is operating normally.
		Blinking	1. The inverter is powered on and in the waiting stage. 2. The inverter is performing a self-check.
		Off	Fault condition is detected.
B	Red indicator	On	Fault condition is detected.
		Off	The inverter is operating without fault.
C	Yellow indicator	On	Communication between the Wi-Fi dongle and the inverter is normal.
		Blinking	No network with WIFI dongle connected to the inverter.
		Off	No communication between the Wi-Fi dongle and the inverter.
D	ESC button	Leave from the current interface or function.	
E	Up button	Move the cursor to the upside or increase the value.	
F	Down button	Move the cursor to the downside or decrease the value.	
G	OK button	Press the button to confirm the selection.	
H	LCD Screen	Display the information of the inverter.	

5.2 LCD operation

Mean Structure:



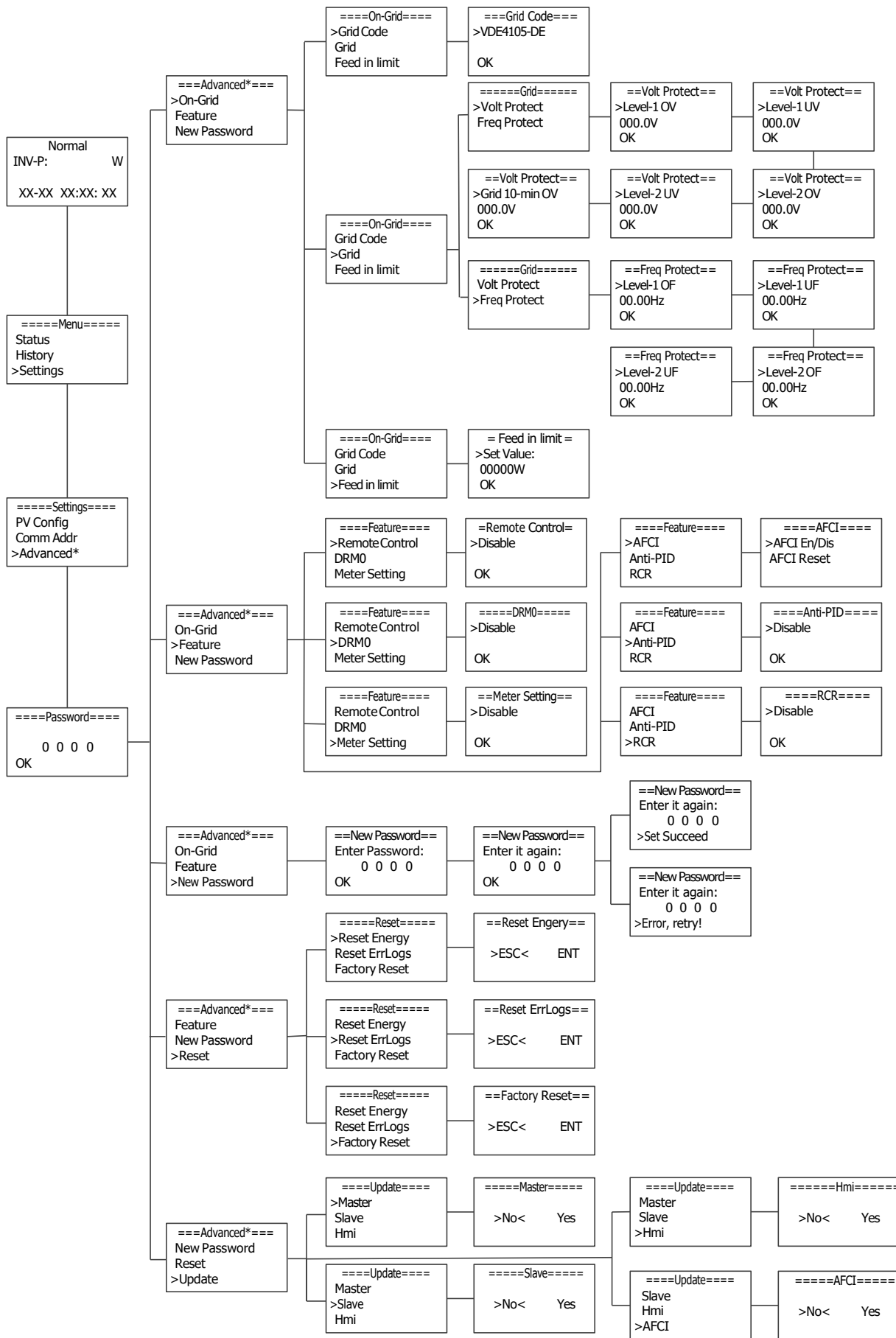

5.2.1 Setting

There are two types of confirmation in the setting function.

1. Press and hold the OK button for 2~3 seconds to confirm the selection. If the setting is successful, 'Set Succeed' will be displayed below; if the setting fails, 'Set Failed' will be displayed below. When 'Set Succeed' or 'Set Failed' appears below, you can press the ESC button to return or press the OK button briefly to re-select. Take setting the language as an example.

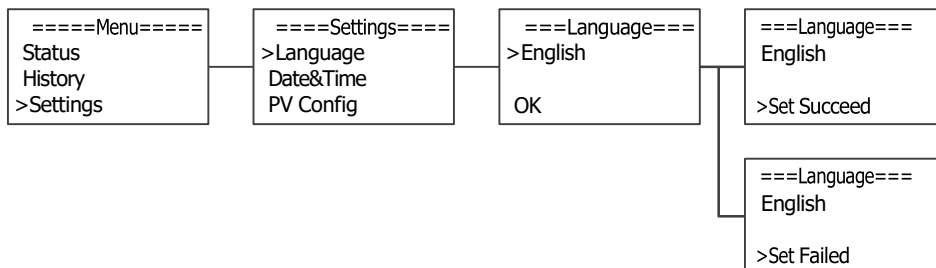

2. Press the OK button briefly to enter the second confirmation interface; users need to select 'ENT' to confirm formally. If the setting is successful, 'Set Succeed' will be displayed below, and the page will automatically return to the previous page in a while; if the setting fails, 'Set Failed' will be displayed below, and the page will be fixed, and the user will need to press the ESC button to return to the previous page. Take setting the language as an example.

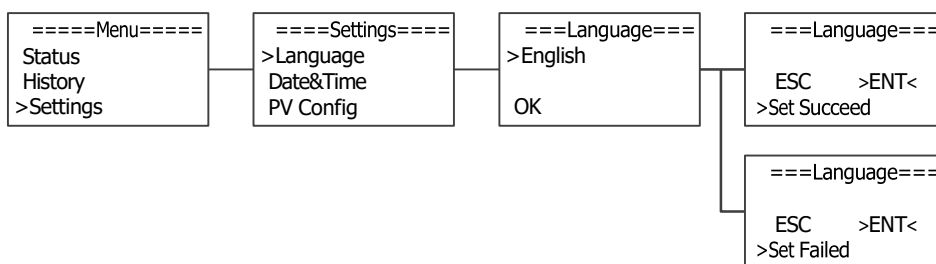

5.2.2 Language setting

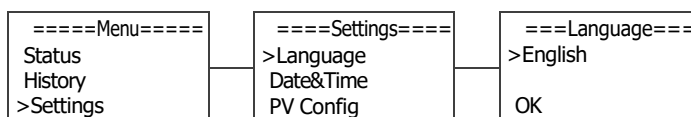

5.2.3 Feed-in limit setting

Step1:

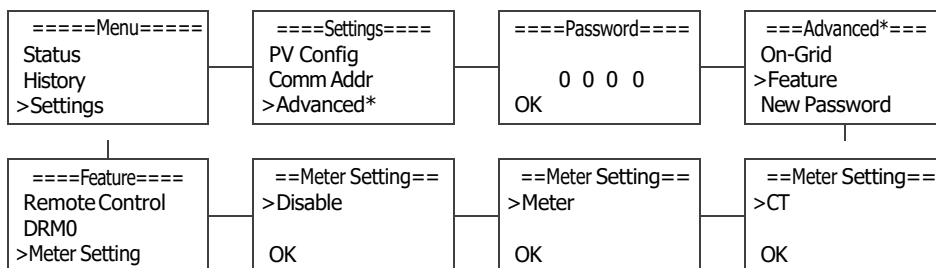

Step2:

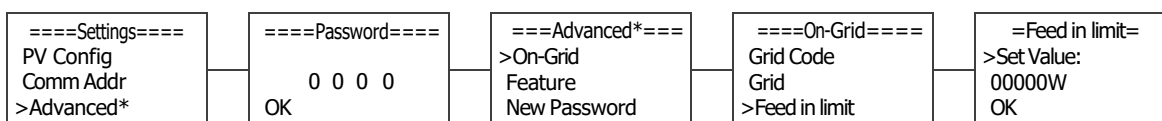

5.2.4 Date and time setting

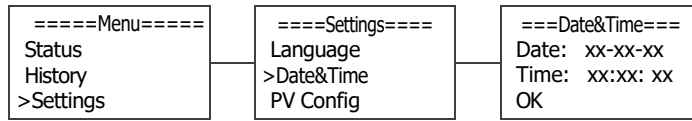

5.2.5 PV configuration setting

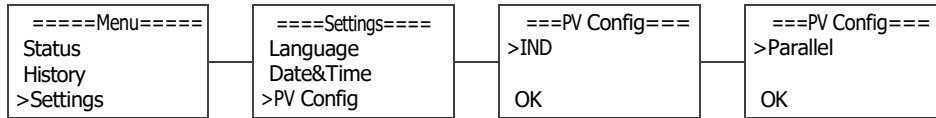

5.2.6 Communication address setting

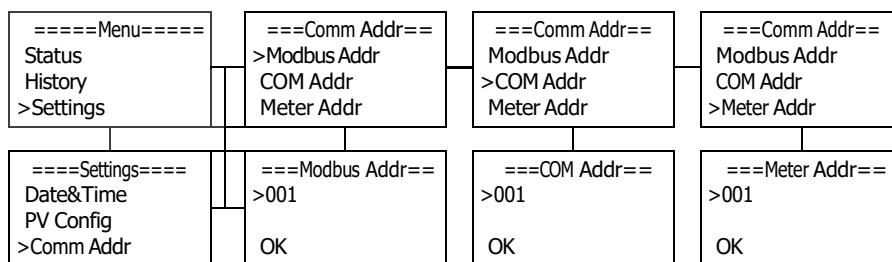

5.2.7 Checking error logs

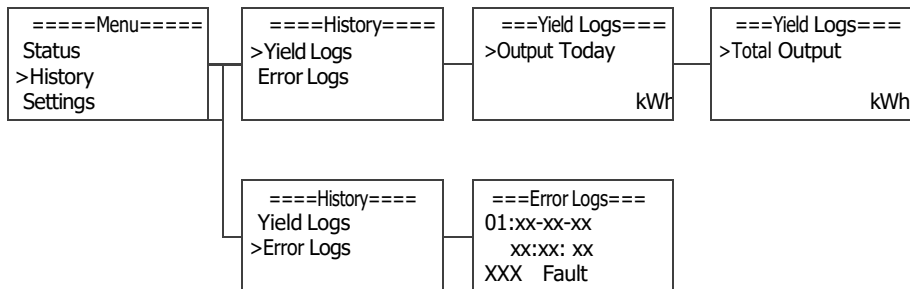

5.2.8 System switch setting

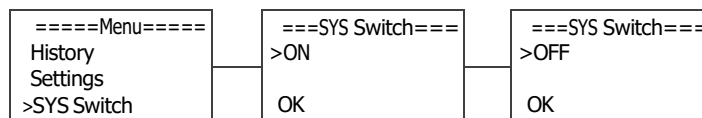

5.2.9 Inverter information checking

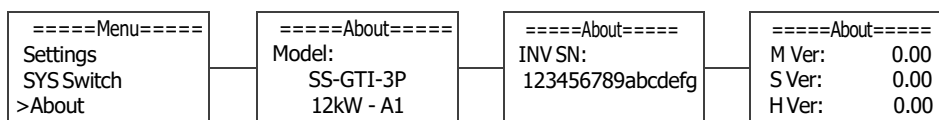

5.2.10 Grid code setting

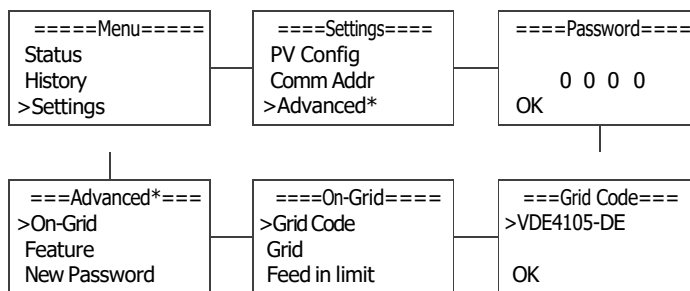

5.2.11 DRMO setting

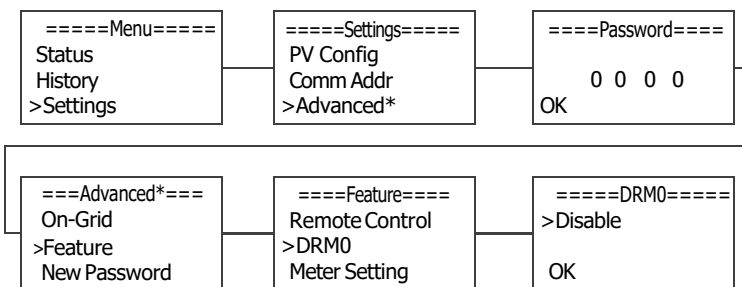

5.2.12 AFCI setting

To enable the AFCI function, you need to set it up. When electric arcs occur, the inverter will alarm and lock out to provide protection. You need to manually clear the alarm on the inverter so that it can work properly.

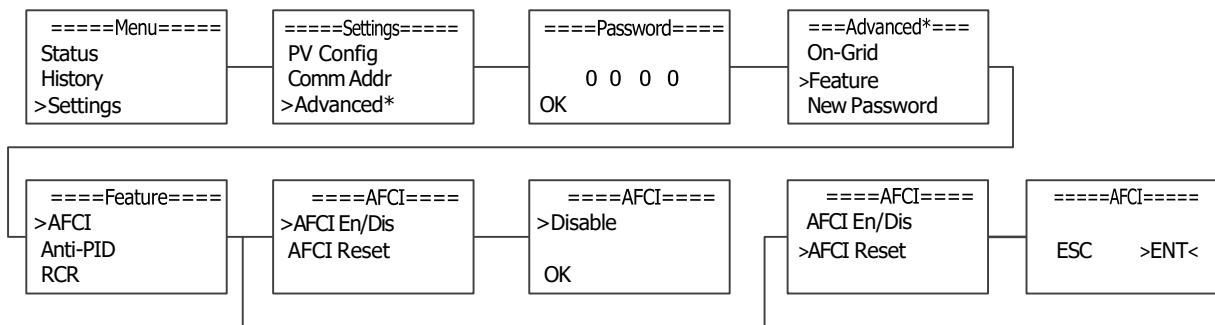

5.2.13 PID setting

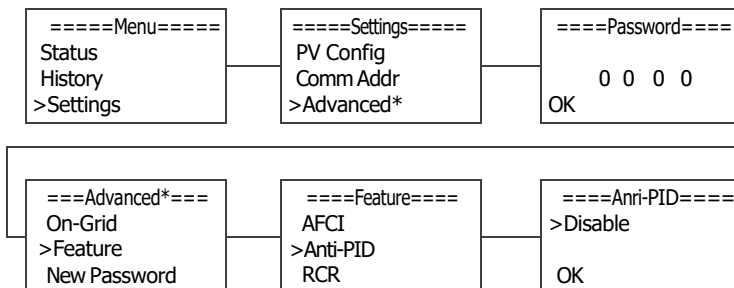

5.2.14 RCR setting

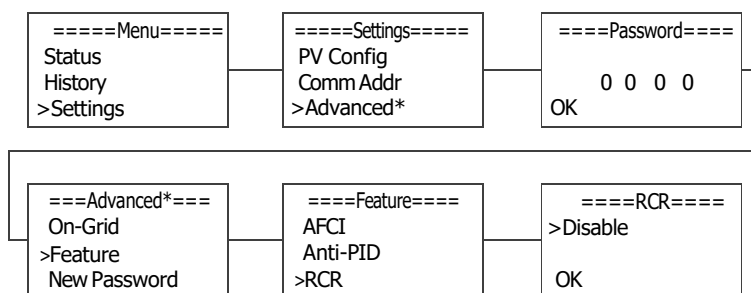

5.2.15 Software update

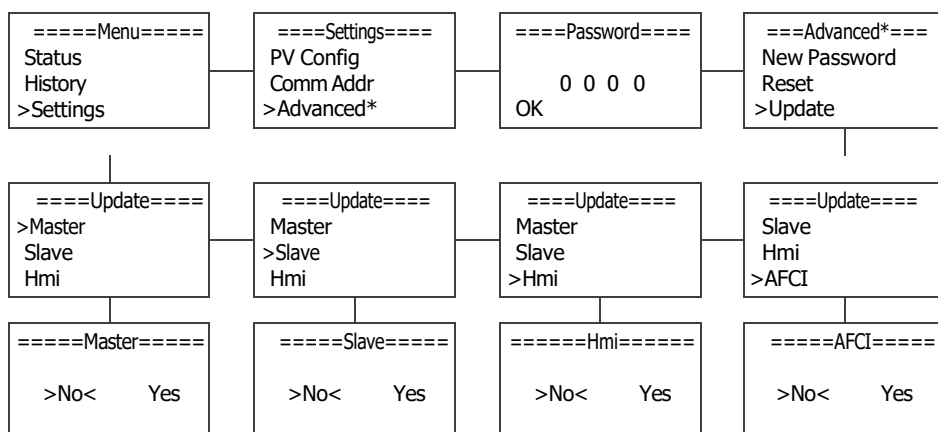

- Step 1: Please contact technicians to obtain the upgrade program.
- Step 2: Insert the USB disk into the computer and copy the upgrade program to the USB disk.
- Step 3: Insert the USB disk into the USB port of the inverter.
- Step 4: Refer to the above figure to upgrade DSPM, DSPS, ARMC, and AFCI, respectively. (The AFCI can only be upgraded when the AFCI function is enabled.)
- Step 5: After the upgrade, the inverter will start to work automatically.

5.2.16 New password setting

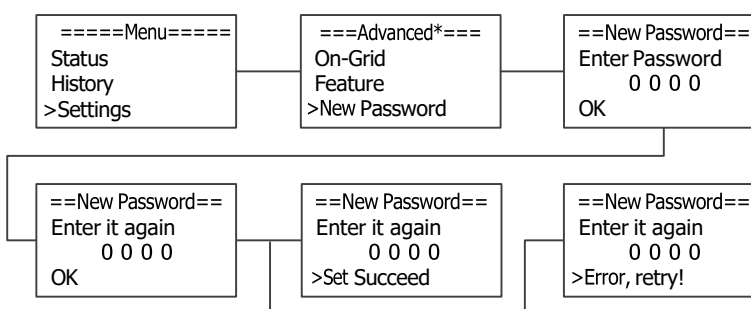

5.2.17 Reset setting

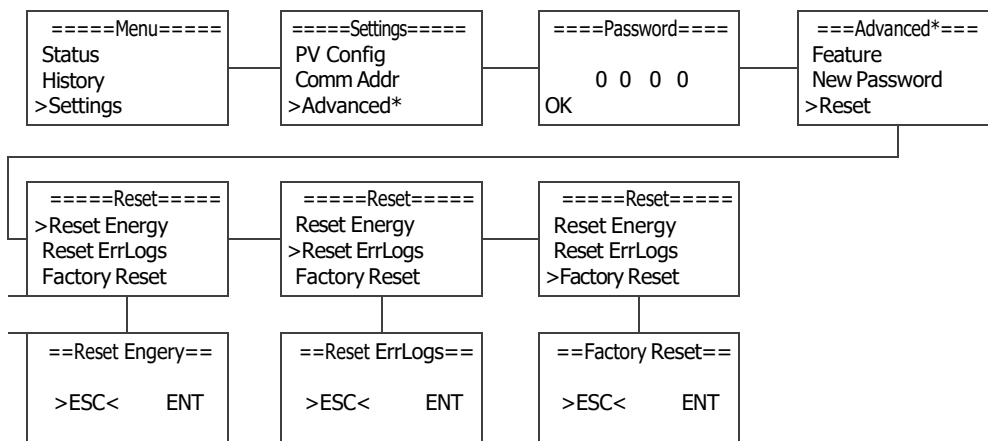

5.3 Self-Test in accordance with CEI 0-21 (Applies to Italy only)

The self-test is only required for inverters, which are commissioned in Italy. The Italian standard requires that all inverters feeding into the utility grid are equipped with a self-test function in accordance with CEI 0-21. Please note that there is a self-test option only when the inverter selects CEI 0-21. During the self-test, the inverter will consecutively check the protection reaction times and values for overvoltage, under voltage, over frequency, and under frequency.

Self-test function is available at any time. It also allows the end user to get test reports shown on the LCD. There are two ways to execute the self-test (You need to set the inverter country to CEI 0-21 before testing).

Self-Test from screen:

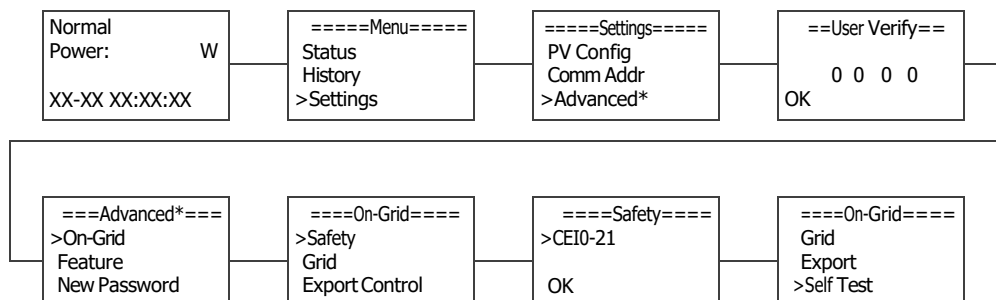

6. Warranty

6.1 Warranty claim procedure

Please report a defective device with a brief error description and SN code to our service mail or service hotline for registration. Alternatively, please contact your specific dealer or installer if your unit is defective.

To claim the warranty under the warranty terms of the factory, you need to supply us with the following information and documentation regarding the faulty unit:

- 1) Product Model and the Serial Number.
- 2) Copy of the invoice and warranty certificate for the inverter.
- 3) Error message on LCD screen and additional information regarding the fault/error.

- 4) Detailed information about the entire system (modules, circuits, etc.).

5) Documentation of previous claim/exchanges (if applicable).

In the case of an exchange, the remainder of the warranty entitlement will be transferred to the replacement device.

In this event, you will not receive a new certificate, as this replacement will be noted by the factory.

6.2 Service after warranty expiration

For products which are out of warranty, the factory charges an on-site service fee, parts, labor cost, and logistic fee to the end-user, which can be any/all of:

- 1) On-site attendance fee: Cost of travel and time for the technician in attending on-site.
- 2) Parts: Cost of replacement parts (including any shipping/admin fee that may apply);
- 3) Labor: Labor time fee charged for the technician, who is repairing, maintaining, and installing (hardware or software) and debugging the faulty product;
- 4) Logistic fee: Cost of delivery, tariff, and other derived expenses when defective products are sent from the user to the factory, or repaired products are sent from the factory to the user.

7. Troubleshooting

Sometimes the PV system does not work normally; we recommend that for low-level solutions for average troubleshooting. This can help the technician understand the problem and take proper action.

No.	LCD	Possible actions
1	Grid Failure	Grid voltage out of range. <ul style="list-style-type: none"> • The system will reconnect if the utility is back to normal. • Or seek help from us, if not, go back to the normal state
2	Grid Volt Fault	Grid voltage out of range. <ul style="list-style-type: none"> • System will reconnect if the utility is back to normal! • Or seek help from us; if not, go back to the normal state.
3	Grid Freq Fault	Grid frequency out of range <ul style="list-style-type: none"> • The system will reconnect if the utility is back to normal. • Or seek help from us; if not, go back to the normal state.
4	PV-V Fault	PV voltage out of range. <ul style="list-style-type: none"> • Please check the output voltage of PV panels. • Or seek help from us.
5	Bus Volt Fault	Bus voltage out of range detected by hardware <ul style="list-style-type: none"> • Disconnect PV, grid, and battery, then reconnect. • Or seek help from us, if not, go back to the normal state
6	Grid 10-min OV	The grid voltage is out of range for the last 10 Minutes. <ul style="list-style-type: none"> • The system will reconnect if the utility is back to normal. • Or seek help from us, if not, go back to the normal state
7	DCI OCP	The DC component is out of limit in the output current. <ul style="list-style-type: none"> • Disconnect PV, grid, and battery, then reconnect. • Or seek help from us; if not, go back to the normal state.

No.	LCD	Possible actions
8	Ground Fault	The inverter is not connected to the ground <ul style="list-style-type: none"> • Please check if the ground connection is normal, then reconnect. • Or seek help from us; if not, go back to the normal state.
9	SW OCP	Output current high detected by software. <ul style="list-style-type: none"> • Disconnect PV, grid, and battery, then reconnect. • Or seek help from us; if not, go back to the normal state.
10	RC OCP	The residual current is high. <ul style="list-style-type: none"> • Please check if the insulation of electric wires is damaged. • Wait for a while to check if back to normal. • Or seek help from us.
11	Iso Check Fault	The isolation has failed. <ul style="list-style-type: none"> • Please check if the insulation of electric wires is damaged. • Wait for a while to check if back to normal. • Or seek help from us.
12	Over TEMP Fault	The inverter temperature is high. <ul style="list-style-type: none"> • Please check the environmental temperature. • Wait for a while to check if back to normal. • Or seek help from us
13	Meter COM Fault	The communication between the meter and the Inverter is interrupted. <ul style="list-style-type: none"> • Check if the communication cable between the meter and the Inverter is correctly and well-connected.
14	Fan Fault	Fan Device Fault <ul style="list-style-type: none"> • Disconnect solar power PV+, PV-, and battery, reconnect them. • Check if the fan is stopped by dust or other foreign matter. • Or seek help from us if you cannot go back to the normal state.
15	PLL Error	The errors are internal faults of the inverter <ul style="list-style-type: none"> • Turn off PV and grid, wait for 5 minutes, then reconnect. • Or seek help from us; if not, go back to the normal state.
16	Island Error	
17	Anti-PID	
18	SCI Fault	
19	Grid Flashover	The errors are internal faults of the inverter <ul style="list-style-type: none"> • Turn off PV and grid, wait for 5 minutes, then reconnect. • Or seek help from us; if not, go back to the normal state.
20	Inv EEPROM Fault	
21	Sample Fault	
22	AFCI Check Fault	The errors are internal faults of the inverter <ul style="list-style-type: none"> • Turn off PV and grid, wait for 5 minutes, then reconnect. • Or seek help from us; if not, go back to the normal state.
23	RCD Fault	
24	Grid RY Short	
25	INV RY Short	The errors are internal faults of the inverter <ul style="list-style-type: none"> • Turn off PV and grid, wait for 5 minutes, then reconnect. • Or seek help from us; if not, go back to the normal state.
26	INV RY Open	
27	Other Device Fault	
28	Grid RY Open	The errors are internal faults of the inverter <ul style="list-style-type: none"> • Turn off PV and grid, wait for 5 minutes, then reconnect. • Or seek help from us; if not, go back to the normal state.
29	AuxVolt Error	
30	Grid-V Mismatch	

No.	LCD	Possible actions
31	Grid-F Mismatch	The errors are internal faults of the inverter
32	Grid-I Mismatch	<ul style="list-style-type: none"> • Turn off PV and grid, wait for 5 minutes, then reconnect. • Or seek help from us; if not, go back to the normal state.
33	RC Consist Fault	
34	SCI Fault	The errors are internal faults of the inverter
35	HMI EEPROM Fault	<ul style="list-style-type: none"> • Turn off PV and grid, wait for 5 minutes, then reconnect. • Or seek help from us; if not, go back to the normal state.

8. Maintenance

	<p>Risk of inverter damage or personal injury due to incorrect service!</p> <ul style="list-style-type: none"> • Always keep in mind that the inverter is powered by dual sources: PV strings and the utility grid. <p>Before any service work, observe the following procedure.</p> <ul style="list-style-type: none"> • Disconnect the AC circuit breaker and then set the DC load-break switch of the inverter to OFF. • Wait at least 5 minutes for inner capacitors to discharge completely. • Verify that there is no voltage or current before pulling any connector.
<h1>NOTICE</h1>	<p>NOTICE !</p> <p>Restart the inverter only after removing the fault that impairs safety performance. As the inverter contains no parts that can be maintained, never arbitrarily replace any internal components. For any maintenance needs, please contact the manufacturer. Otherwise, the manufacturer shall not be held liable for any damage caused.</p>

8.1 Routine Maintenance

Item	LCD	Period
System clean	Check the temperature and dust of the inverter. Clean the inverter enclosure if necessary. Check if the air inlet and outlet are normal. Clean the air inlet and outlet if necessary.	Six months to a year (depending on the dust contents in the air).
Cable entry	Check whether the cable entry is insufficiently sealed or the gap is excessively large, and reseal the entry when necessary.	Once a year
Electrical Connection	Check whether all cables are firmly in place. Check whether a cable is damaged, especially the part contacting the metal enclosure.	Six months to a year

Maintenance Instruction:

Cleaning Air Inlet and Outlet

A huge amount of heat is generated in the process of running the inverter. The inverter adopts a controlled forced-air cooling method. In order to maintain good ventilation, please check to make sure the air inlet and outlet are not blocked. Clean the air inlet and outlet with a soft brush or vacuum cleaner if necessary.

