

# UDAY SERIES



## User Manual

SS-GTI-1P 1.1kW-A1

SS-GTI-1P 2.2kW-A1

SS-GTI-1P 2.5kW-A1

SS-GTI-1P 2.7kW-A1

SS-GTI-1P 3kW-A1

SS-GTI-1P 3.3kW-A1



# Content

<b>1. Introduction</b>	<b>4</b>
1.1 Introduction	4
1.2 Applied designations	4
1.3 Important safety information	5
1.4 System sizing	5
<b>2. Technical description of inverters</b>	<b>6</b>
2.1 Mechanical design	6
2.2 Electrical system design	7
2.3 Technical data	7
2.4 Grid codes	9
<b>3. Installation and startup</b>	<b>10</b>
3.1 Package information	11
3.2 Installation environment	11
3.3 Installation position	12
3.4 Mounting procedure	12
3.5 Electrical connection	14
3.5.1 Earth connection	14
3.5.2 Grid connection (AC output)	14
3.5.3 PV connection (DC input)	16
3.5.4 Communication	17
3.6 Starting the inverter	17
<b>4. User interface</b>	<b>18</b>
4.1 Led and key	18
4.2 LCD display	20
4.3 History	21
4.4 Setting	21
4.4.1 Language	22
4.4.2 Date and time	22
4.4.3 Grid code	22
4.4.4 Feed in limit	22
4.4.5 New password	23
4.4.6 Reset	23

4.5 System switch .....	23
4.6 About .....	23
<b>5. Warranty .....</b>	<b>24</b>
5.1 Warranty claim procedure .....	24
5.2 Service after warranty expiration .....	24
<b>6. Troubleshooting and maintenance .....</b>	<b>24</b>
6.1 Troubleshooting .....	24
6.2 Maintenance.....	26
6.2.1 Routine Maintenance .....	26

## Notice

This manual contains important safety instructions, installation, electrical connections, commissioning, maintenance, and troubleshooting of the equipment.

## Save the manual!

This manual must be stored carefully and be available at all times.

## 1. Introduction

### 1.1 Introduction









This manual describes solar inverters: SS-GTI-1P 1.1KW-A1/SS-GTI-1P 2.2KW-A1/SS-GTI-1P 2.5KW-A1/SS-GTI-1P 2.7KW-A1/SS-GTI-1P 3KW-A1/SS-GTI-1P 3.3KW-A1.

These inverters are transformerless based inverter.

Please read the safety instructions in this manual first. Throughout the manual it is assumed that the reader is familiar with AC and DC installations and knows the rules and regulations for electrical equipment and for connecting it to the utility AC grid. It is especially important to be familiar with the general safety rules for working with electrical equipment.

### 1.2 Applied designations

Throughout the manual important information is shown at different levels depending on the character of the information, as shown here:

	Safety information important for human safety. Violation of warnings may result in injury to persons or death.
	Danger of high voltage and electric shock!
	Signals danger due to electrical shock and indicates the time (5 minutes) to allow after the inverter has been turned off and disconnected to ensure safety in any installation operation.
	Danger of hot surface!
	Product should not be disposed as normal household waste.
	CE Mark
	ROHS Mark
	Information important for the protection of property. Violation of this type of information may cause damage and loss of property.
	Useful additional information or "Tips and Tricks" on specific subjects.

### 1.3 Important safety information

Read this before installing, operating or maintaining the inverter.

	<p><b>Before installation:</b></p> <p>Check for damage to inverter and packaging. If you are in doubt, please contact your supplier before installing the inverter. Check the voltages of the solar modules and make sure they are within the limits of the inverter specifications before connecting them to the inverter.</p>
	<p><b>Installation:</b></p> <p>Only trained and authorized personnel familiar with local electrical codes may install the inverter. For optimum safety, please follow the steps described in this manual. Keep in mind that the inverter has two voltage carrying sides, the PV input and the AC grid.</p>
	<p><b>Disconnecting the inverter:</b></p> <p>Always disconnect the AC line first! Afterwards disconnect the PV lines. Note that the inverter can still be charged with very high voltages at hazardous levels even when it is disconnected from grid and solar modules. Wait at least 5 min, before proceeding, after having disconnected from grid and PV panels.</p>
	<p><b>Operating the inverter:</b></p> <p>Before connecting the AC grid to the inverter, make sure that the installation cover is mounted again. The inverter must not be open during operation.</p>
	<p><b>Maintenance and modification:</b></p> <p>Only authorized personnel are allowed to repair or modify the inverter. To ensure optimum safety for user and environment, only the original spare parts available from your supplier should be used.</p>
	<p><b>Functional safety parameters:</b></p> <p>Unauthorized changes of functional safety parameters may cause injury or accidents to people or inverter. Additionally it will lead to the cancelling of all inverter operating approval certificates.</p>

### 1.4 System sizing

	<p>When dimensioning a photovoltaic system, it must be ensured that the open circuit voltage of the PV string never exceeds the maximum permissible input voltage. The maximum input voltage for SS-GTI-1P 1.1kW-A1/SS-GTI-1P 2.2kW-A1/SS-GTI-1P 2.5kW-A1 inverters is 500VDC. The maximum input voltage for SS-GTI-1P 2.7kW-A1/SS-GTI-1P 3kW-A1/SS-GTI-1P 3.3kW-A1 inverters is 550VDC. Higher voltages may result in permanent damage to the inverter.</p>
---	--

The selection of PV string output should be based on the optimum utilization of the invested capital compared to the expected annual energy yield from the system. This optimization depends on local weather conditions and should be considered in each individual case.

The inverter incorporates an input power limiting device which automatically keeps the power at levels that are safe for the inverter. The limitation depends mainly on internal and ambient temperatures. The limitation is calculated continuously and always allows the maximum possible amount of energy to be produced.

Please use the tool supplied by manufacturer when dimensioning a photovoltaic system.

## 2. Technical description of inverters

### 2.1 Mechanical design

Figure 2-1 shows the outline dimensions of SS-GTI-1P 1.1KW-A1/SS-GTI-1P 2.2KW-A1/SS-GTI-1P 2.5KW-A1/SS-GTI-1P 2.7KW-A1/SS-GTI-1P 3KW-A1/SS-GTI-1P 3.3KW-A1.

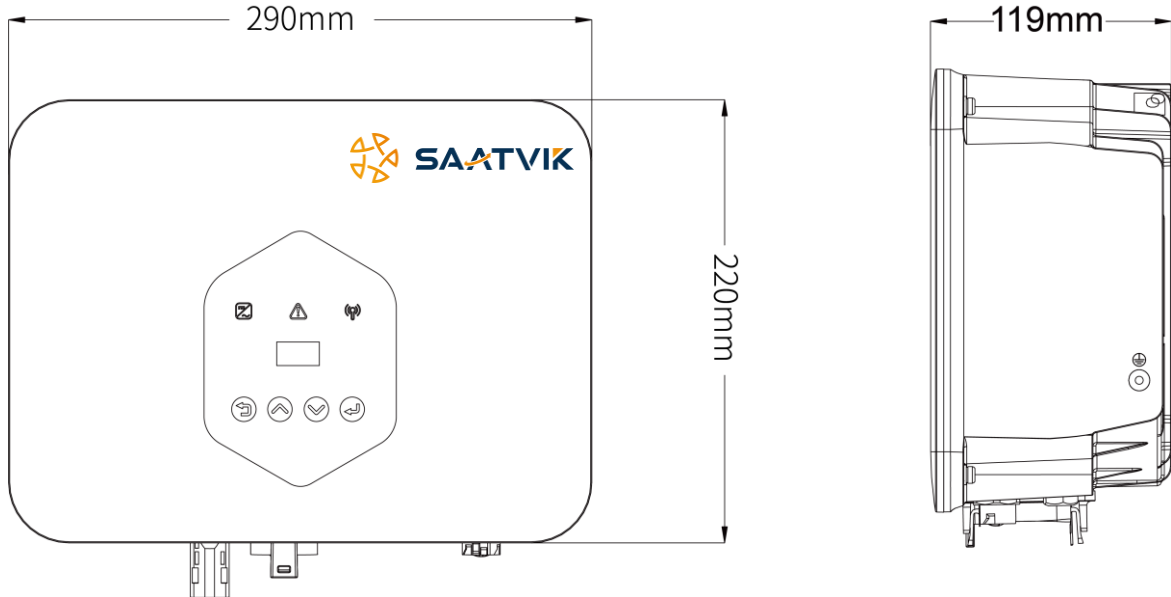

Figure 2-1 Outline dimensions

Figure 2-2 shows the electrical terminals of SS-GTI-1P 1.1KW-A1/SS-GTI-1P 2.2KW-A1/SS-GTI-1P 2.5KW-A1/SS-GTI-1P 2.7KW-A1/SS-GTI-1P 3KW-A1/SS-GTI-1P 3.3KW-A1.

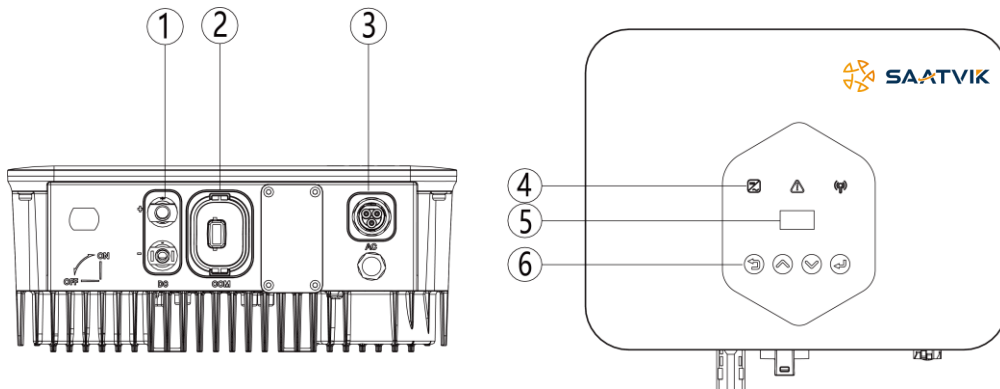

Figure 2-2 Electrical Terminals

No.	Description	No.	Description
1	DC terminal	4	LED (Run / Fault)
2	Communication port	5	OLED
3	AC terminal	6	Key

## 2.2 Electrical system design



For safety reasons, the use of a DC switch is recommended. Between the PV modules and the power modules may be mandatory in some countries

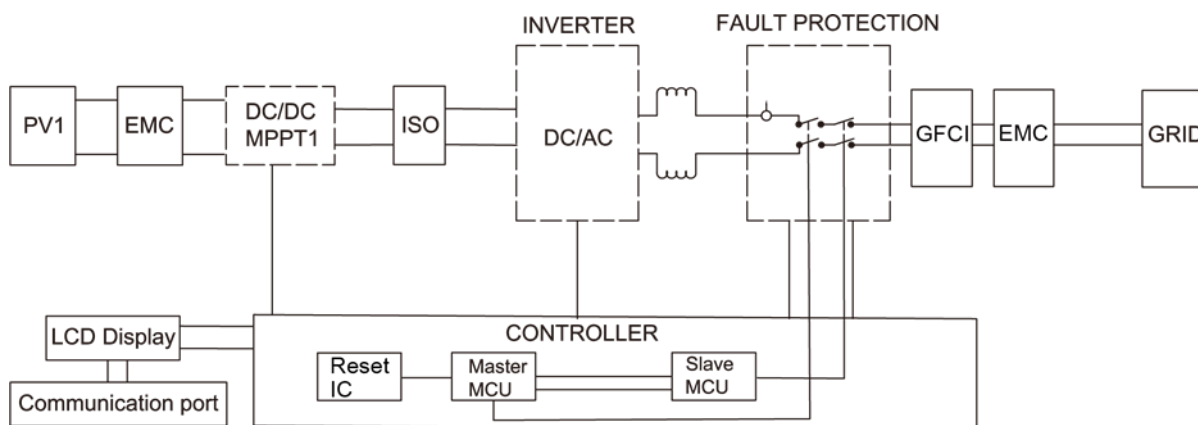

Figure 2-3 Block diagram of the inverter system

## 2.3 Technical data

Model	SS-GTI-1P 1.1KW-A1	SS-GTI-1P 2.2KW-A1	SS-GTI-1P 2.5KW-A1	SS-GTI-1P 2.7KW-A1	SS-GTI-1P 3KW-A1	SS-GTI-1P 3.3KW-A1
<b>PV Input</b>						
Max. Recommended PV Power [Wp]	1650	3300	3750	4050	4500	4950
Max. PV Input Voltage [V]	500			550		
MPPT Voltage Range [V]	45 ~ 500			50 ~ 550		
Rated PV Input Voltage [V]	360					
Start-up Voltage [V]	70					
No. of MPP Trackers	1					
No. of Input Strings per Tracker	1					
Max. PV Input Current [A]	18					
Max. Short-circuit Current [A]	23					
<b>AC Output</b>						
Rated AC Output Power [W]	1100	2200	2500	2700	3000	3300
Max. AC Output Apparent Power [VA]	1100	2200	2500	2700	3000	3300
Rated AC Voltage / Range [V]	L / N / PE, 220 / 230; 160 ~ 290					
Grid Frequency / Range [Hz]	50 / 60					
Adjustable Power Factor [cosφ]	0.8 leading ~ 0.8 lagging					
Output THDi [@Rated Output]	< 3%					
Max. AC Output Current [A]	5	10	11.4	12.3	13.6	15
Max. Output Fault Current	44.12					

Model	SS-GTI-1P 1.1KW-A1	SS-GTI-1P 2.2KW-A1	SS-GTI-1P 2.5KW-A1	SS-GTI-1P 2.7KW-A1	SS-GTI-1P 3KW-A1	SS-GTI-1P 3.3KW-A1
(Peak and Duration) (A)						
<b>Efficiency</b>						
Max. Efficiency	97.5%	97.5%	97.5%	97.6%	97.6%	97.6%
Euro Efficiency	96.9%	96.9%	96.9%	97.2%	97.2%	97.2%
<b>Protection</b>						
DC Insulation Monitoring	Integrated					
Input Reverse Polarity Protection	Integrated					
Anti-island Protection	Integrated					
Residual Current Monitoring	Integrated					
AC Overcurrent Protection	Integrated					
AC Short-circuit Protection	Integrated					
DC Surge Protection	Integrated (Type II)					
AC Surge Protection	Integrated (Type II)					
Arc Fault Circuit Interrupter (AFCI)	Optional					
DC Switch	Optional					
<b>General Data</b>						
Dimensions (W * H * D) [mm]	290 * 220 * 119					
Weight [kg]	5.5					
Display	LED + OLED					
Communication	Optional: WIFI, 4G, Ethernet					
Ambient Temperature Range [°C]	-25 ~ +60					
Relative Humidity	0 ~ 100%					
Operating Altitude [m]	≤ 2000					
Night Self-consumption [W]	< 1					
Topology	Transformerless					
Cooling	Natural					
Protection Grades	IP65					
Pollution Degree	III					
Overvoltage Category	DC II / AC III					
Protective class	I					
Noise [dB]	< 25					

## 2.4 Grid codes

No.	National/Regional Grid Code	Description
0	VDE4105-DE	Germany power Grid, meet Grid standards "VDE-AR-N-4105".
1	CEI0-21	Italy power Grid.
2	Australia A	Australia A power Grid.
3	RD1699	Spain power Grid.
4	EN50549	Default EN50549 Grid setting.
5	EN50549-DK-W	West Denmark power Grid.
6	Greece	Greece power Grid.
7	EN50549-NL	Netherland power Grid.
8	C10/11	Belgium power Grid.
9	G99	UK power Grid.
10	China	China power Grid, meet Grid standards "CN-NBT".
11	VDE0126-FR	France power Grid, meet Grid standards "VDE 0126".
12	EN50549-PL	Poland power Grid.
13	Brazil-180s	Brazil power Grid, connect/reconnect time 180s.
14	VDE0126-DE	Germany power Grid, meet Grid standards "VDE 0126".
15	CEI0-16	Italy power Grid, meet Grid standards "CEI0-16".
16	G98	UK power Grid.
17	Greece Island	Greece Island power Grid.
18	EN50549-CZ	Czech Republic power Grid.
19	IEC61727-IN	India power Grid.
20	Korea	Korea power Grid.
21	EN50549-SW	Sweden power Grid.
22	China-W	China power Grid, Grid voltage range: 160-264.5V. Grid frequency range: 47-52Hz.
23	China-H	China power Grid. Grid voltage range: 160-280V.
24	IEC61727-IN-W	India power Grid. Grid voltage range: 195.5-280V.
25	Brazil	Brazil power Grid, meet Grid standards "NBT 16150".
26	IEC61727-SL	Sri Lanka power Grid, meet Grid standards "IEC61727".
27	Mexico	Mexico power Grid, meet Grid standards "IEC61727 60Hz".
28	New Zealand	New Zealand power Grid.
29	Philippines	Philippines power Grid, meet Grid standards "IEC61727 60Hz".
30	IEC61727-SL-W	Sri Lanka power Grid, Grid voltage range: 160-280V. Grid frequency range: 47-52Hz.
31	PEA	Thailand power Grid.
32	PEA-W	Thailand power Grid. Grid voltage range: 160-280V. Grid frequency range: 47-52Hz.
33	IEC61627-VN	Vietnam power Grid.
34	IEC61627-VN-W	Vietnam power Grid. Grid voltage range: 160-280V. Grid frequency range: 47-52Hz.
35	Tunisia	Tunisia.

No.	National/Regional Grid Code	Description
36	MEA	Thailand power Grid.
37	MEA-W	Thailand power Grid. Grid voltage range: 160-280V. Grid frequency range: 47-52Hz.
38	Brazil-LV	120V 60Hz voltage of grid L to N (R3-10-15K-LV only, others reserved).
39	EN50549-DK-E	East Denmark power Grid.
40	Tunisia-W	Tunisia wide range. Grid voltage range: 160-290V.
41	Chile	Chile Power Grid.
42	Brazil-W	Brazil power Grid. Grid voltage range: 160-290V.
43	EN50549-PL-W	Poland power Grid. Grid voltage range: 160-290V.
44	Brazil-180s-W	Brazil power Grid. Grid voltage range: 160-290V.
45	UNE217002-ES	Spain power Grid.
46	G98-NI	G98 for Northern Ireland.
47	G99-NI	G99 for Northern Ireland.
48	EN50549-NW	Norway-400VLine
49	EN50549-NW-LV	Norway-230VLine-R3-10-15K-LV only, others reserved.
50	IEC61727-LV	133V 50Hz, low voltage power grid.
51	EN50549-IR*/	Ireland power Grid.
52	Austria	Austria power Grid.
53	Australia B	Australia B power Grid.
54	Australia C	Australia C power Grid.
55	EN50549-SIST	Slovenia Grid.
56	EN50549-HUN	Hungary Grid.
57	Pakistan	Pakistan Grid.

### 3. Installation and startup



#### WARNING !

Before installation and maintenance, AC and DC side doesn't carry electricity, but if DC side is just disconnected, capacitance still contains electricity, so please wait for at least 5 minutes to ensure the capacitors completely release the energy and inverter is not electrified.



#### NOTE !

Inverters must be installed by qualified person.

### 3.1 Package information

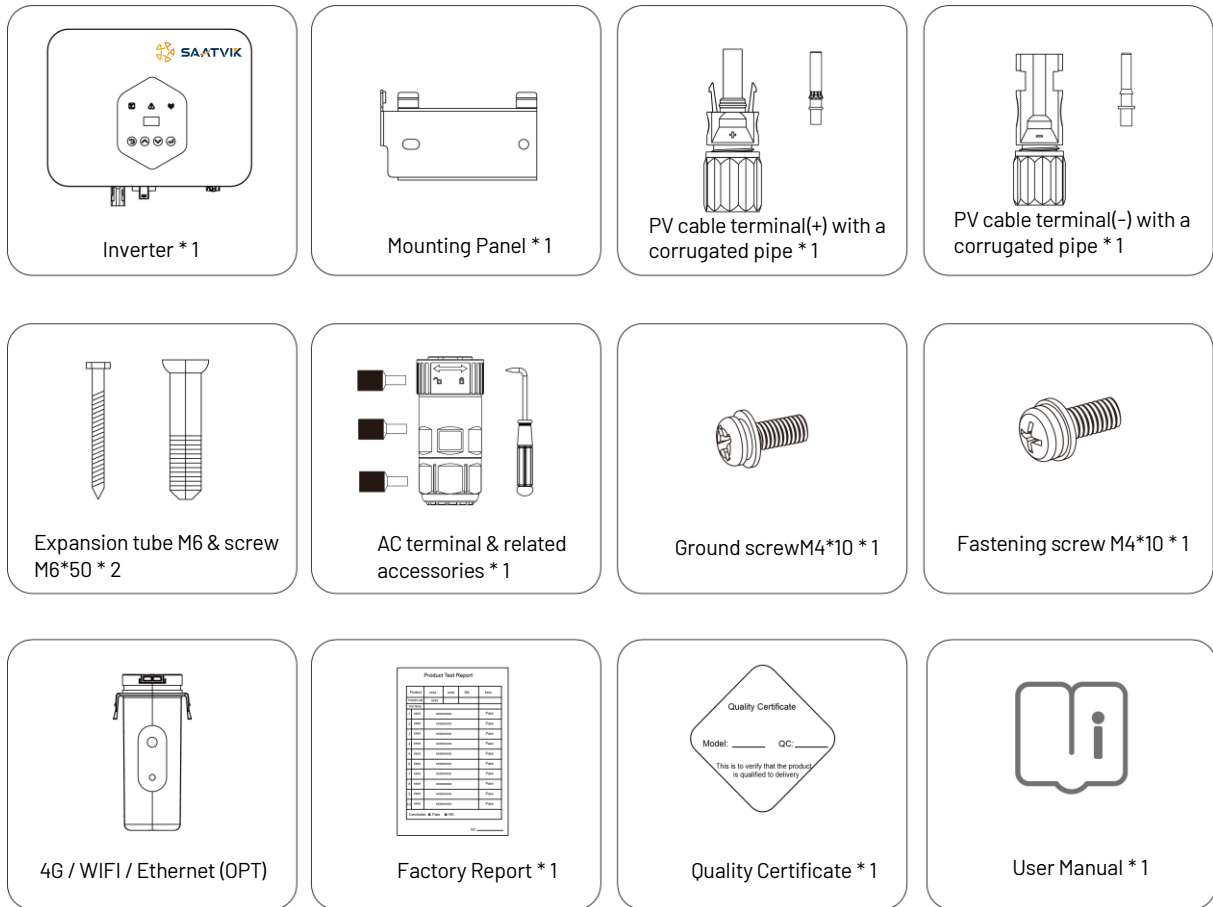

Figure 3-1 Package information

### 3.2 Installation environment

- 1) In order to achieve optimal performance, the ambient temperature should be kept lower than 45 °C.
- 2) For the convenience of checking the LCD display and possible maintenance activities, please install the inverter at eye level.
- 3) Inverters should not be installed near inflammable or explosive items. Any strong electro-magnetic equipment should be kept away from installation site.
- 4) Product label and warning symbol shall be clear to read after installation.
- 5) Please do not install inverter under direct sunlight, rain and snow.

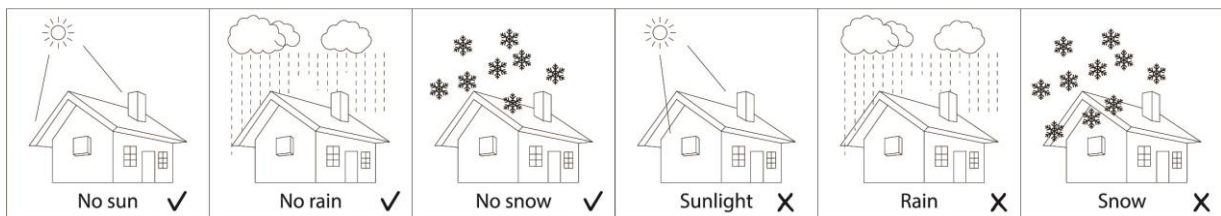

Figure 3-2 Installation environment

### 3.3 Installation position

<b>!</b>	<ol style="list-style-type: none"> <li>1) The installation method and mounting location must be suitable for the inverter's weight and dimensions.</li> <li>2) Mount on a solid surface.</li> <li>3) Select a well-ventilated place sheltered from direct sun radiation.</li> </ol>
----------	---

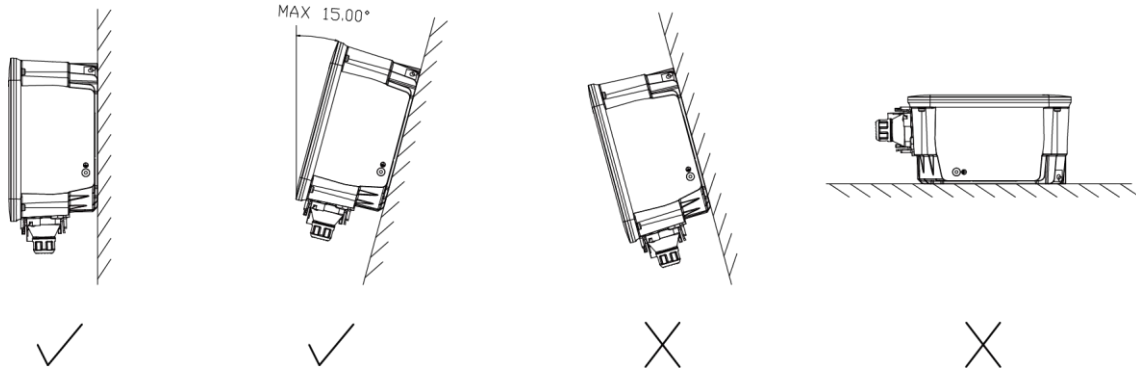

Figure 3-3 Installation position

In consideration of heat dissipation and convenient dismantlement, the minimum clearances around the inverter should be no less than the following value.

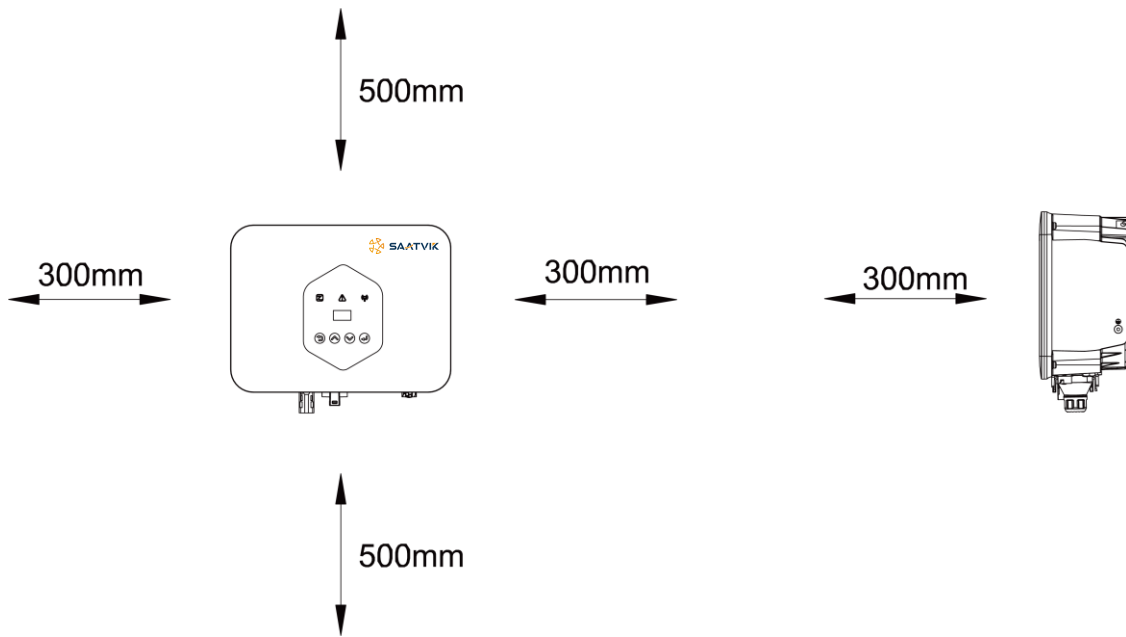

Figure 3-4 Distance required of Inverters

### 3.4 Mounting procedure

1. Drill 2 Fix  $\Phi 11$  holes in the wall according to the dimensions.
2. Fix the wall mounting bracket on the wall with 2 expansion bolts in accessory bag.

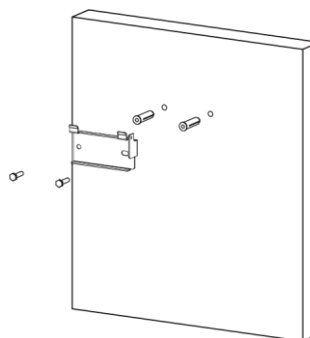
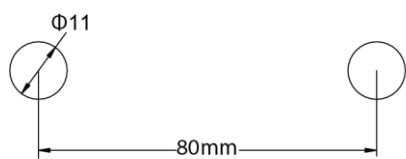

Figure 3-5

3. Place the inverter on the wall-mounted bracket.

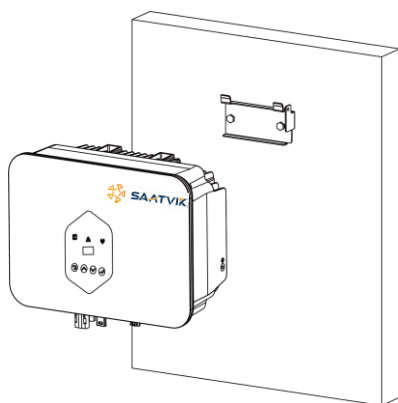

Figure 3-6

4. Place install the fix screw to fix the inverter.

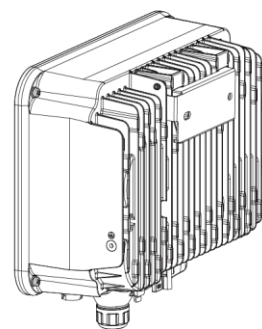
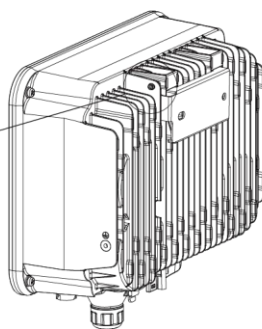
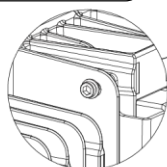
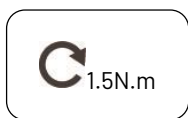

Figure 3-7

### 3.5 Electrical connection

#### 3.5.1 Earth connection

One can additionally earth the inverter enclosure of a second earthed or equipotential bonding, which is required under local regulations. This prevents touch current if the original protective conductor fails.

Cable size: 4mm<sup>2</sup>

**Connection steps:**

- Strip the earthed cable insulation.
- Insert the stripped cable into the ring terminal.
- Clamp the end of the ring terminal.
- Unscrew the screw of the earthed connector.
- Insert the ring terminal on the earthed connector.
- Fix the gasket on the earthed connector.
- Tighten the screw of the earthed connector.

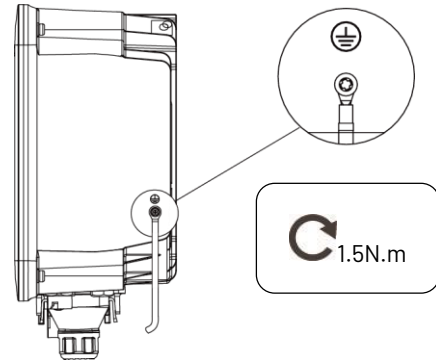

Figure 3-8

#### 3.5.2 Grid connection (AC output)



- 1) Add breaker or fuse to AC side, the specification should be more than 1.25 times of rated AC output current.
- 2) The PE line of inverter should be connected to the earth, make sure the impedance of neutral wire and earth wire less than 10 ohm.
- 3) Disconnect the breaker or fuse between the inverter and the utility.
- 4) All inverters incorporate a certified internal Residual Current Device (RCD) in order to protect against possible electrocution and fire hazard in case of a malfunction in the PV array, cables or inverter. There are 2 trip thresholds for the RCD as required for certification (IEC 62109-2:2011). The default value for electrocution protection is 30mA, and for slow rising current is 300mA.

Connect the inverter to the grid as follows:

1. Strip off L/N/PE cables.

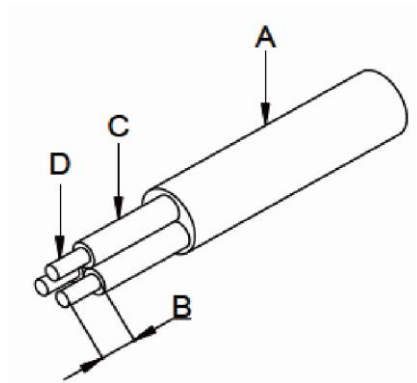

Figure 3-9 Strip off PE/N/L cables

No.	Description	Remark
A	Protective layer	Diameter ranges : 10-12mm
B	Length of stripped off	12mm
C	Insulate layer	50mm
D	Cross section of ac cables	2.5mm <sup>2</sup>

2. Crimp the terminals with crimping pliers and set the parts on the cable. Insert the terminal holes in sequence.

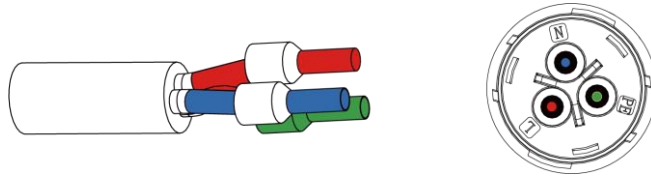

Figure 3-10

3. Fully insert the conductors to the corresponding terminal and tighten the screws with the torque 0.8 N.m. Pull cables outward to check whether they are firmly installed.

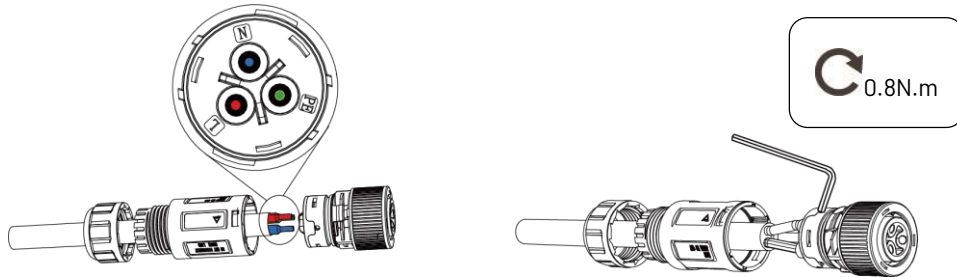

Figure 3-11

4. Assemble the housing, the terminal block and cable gland (torque 4 N.m-5 N.m). Make sure that the rib of the terminal block and the groove on the housing engage perfectly until a 'Click' is heard or felt.

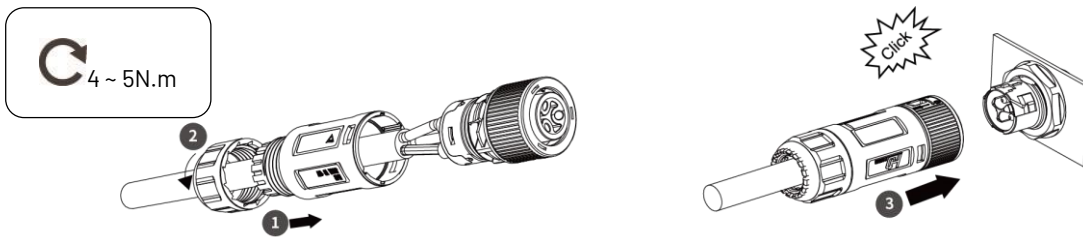

Figure 3-12

**Unlock AC terminal instructions**

1. Use the disassembly tool to flip the installation icon to the unlock icon.

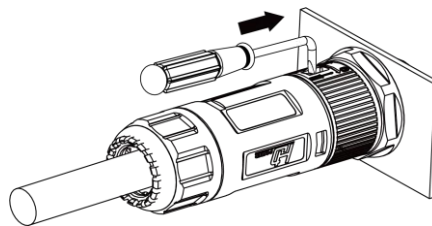

Figure 3-13

2. Rotate the latch as shown.

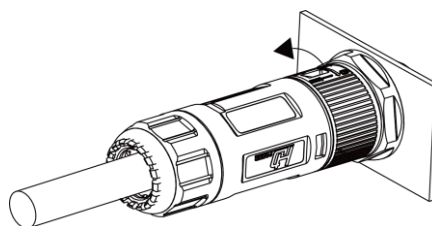

Figure 3-14

3. Remove the female end of the cable to unlock the account.

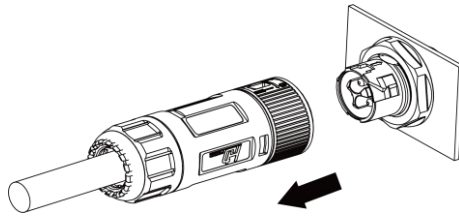

Figure 3-15

3.5.3 PV connection (DC input)



- 1) Before connecting PV string, make sure DC switch is turned off.
- 2) Make sure PV string polarity confirms with DC connector, otherwise, it will cause damage to inverter.
- 3) Make sure the maximum open circuit voltage (Voc) of each PV string does not exceed the inverter input voltage  $V_{max}$  under any condition.
- 4) Do not connect positive or negative pole of PV string to earth wire. Otherwise, it will cause damage to inverter.

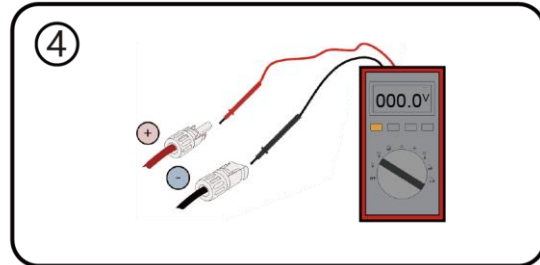
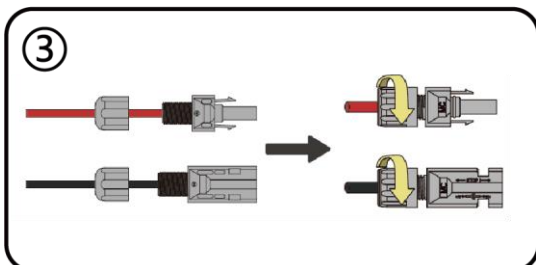
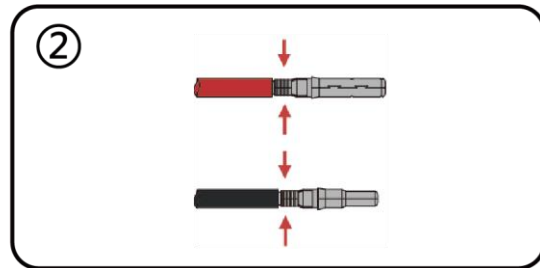
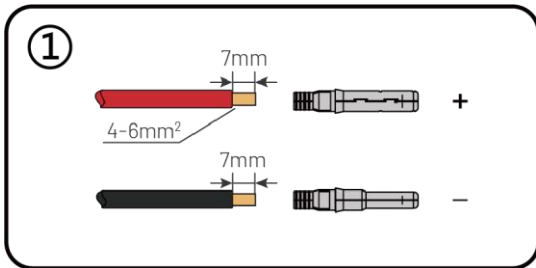

Figure 3-16

### 3.5.4 Communication

Overview of COM port:

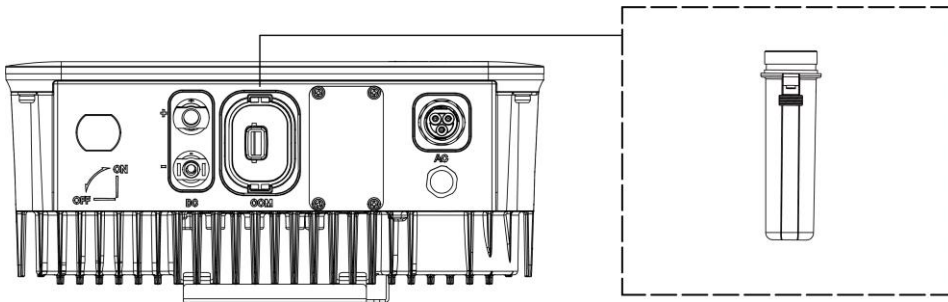

Figure 3-17 COM port

Connect the WIFI / 4G / Ethernet module produced by manufacturer to the COM port of inverter. After successful connection, information such as power generation and running state of the inverter can be viewed via the App on the phone. The details please refer to the WIFI / 4G / Ethernet module user manual.

The block diagram of the WIFI / 4G / Ethernet communication system is as follows:

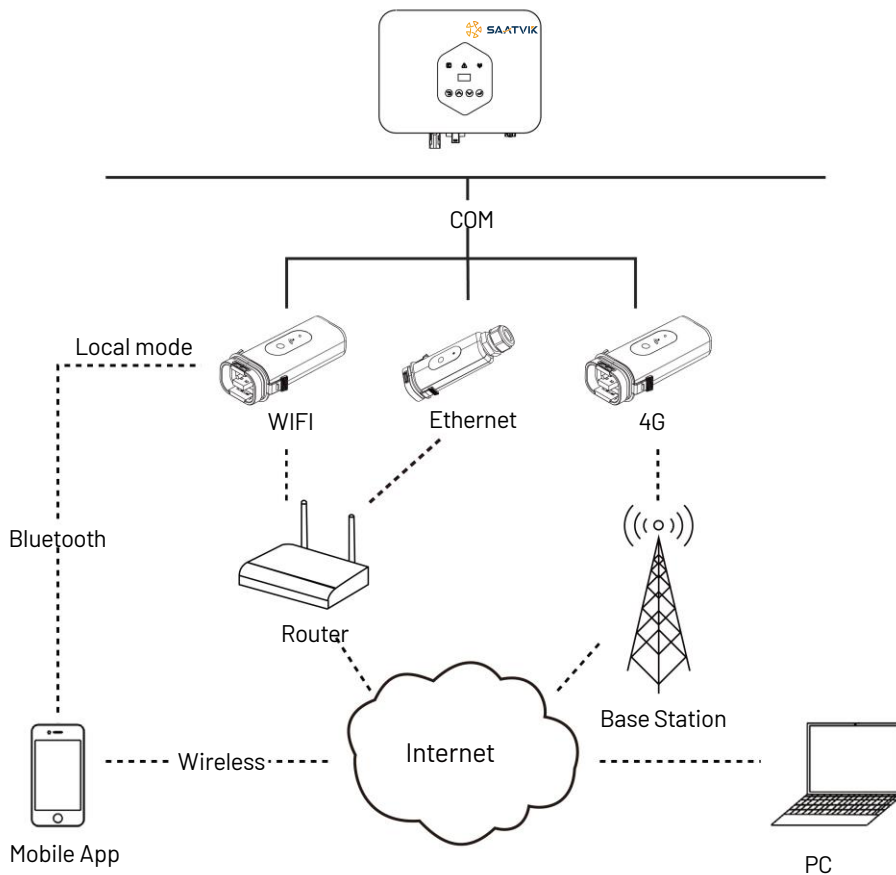

Figure 3-18

### 3.6 Starting the inverter

Before turning on the inverter, please confirm:

- 1) Three AC wires (PE/L/N) cable correctly connected to the inverter AC side through AC circuit breaker;
- 2) The DC cable is connected correctly to the DC side of the inverter through the DC circuit breaker; please pay attention to the cable connected to the string correctly and its polarity;
- 3) The unused terminals are covered.

Starting the inverter:

- 1) Turn on the AC circuit breaker between the inverter and the grid;
- 3) If the PV panels provide enough energy, the power module will work, and the LCD panel will be lit;
- 4) Then the inverter will turn into self-check mode, and the LCD panel will display the remaining time of connection simultaneously;
- 5) If you are starting the inverter for the first time, the inverter needs to be commissioned. For example, language, time, etc.
- 6) After the inverter turns into normal mode, it feeds electrical energy into the grid, and the LCD panel will display the generated electrical energy.

As long as the inverter works, it will automatically track the maximum power point to absorb the maximum energy from solar. When night comes, the irradiance is not strong enough to provide energy, and the inverter will power off automatically. When the next day comes, the input voltage reaches the start value, and it will start again automatically.

## 4. User interface

### 4.1 Led and key

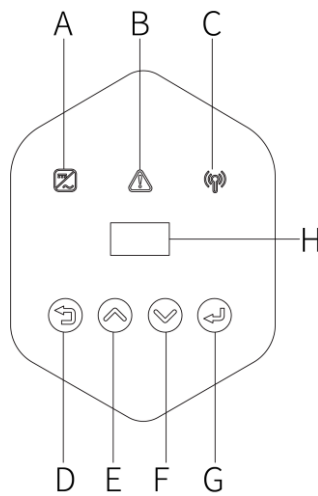

Figure 4-1 LED display

No.	Name	Description	
A	Green indicator	On	The inverter has connected to the grid and is operating normally.
		Blinking	1. The inverter is powered on and in the waiting stage. 2. The inverter is performing self-check.
		Off	Fault condition is detected.
B	Red indicator	On	Fault condition is detected.
		Off	The inverter is operating without fault.
C	Yellow indicator	On	Communication between WIFI dongle and the inverter is normal.

No.	Name	Description	
		Blinking	No network with WIFI dongle connected to the inverter.
		Off	No communication between WIFI dongle and the inverter.
D	ESC button	Leave from current interface or function.	
E	Up button	Move cursor to upside or increase value.	
F	Down button	Move cursor to downside or decrease value.	
G	OK button	Press the button to confirm the selection.	
H	LCD Screen	Display the information of the inverter.	

### 4.2 LCD display

Mean Structure:

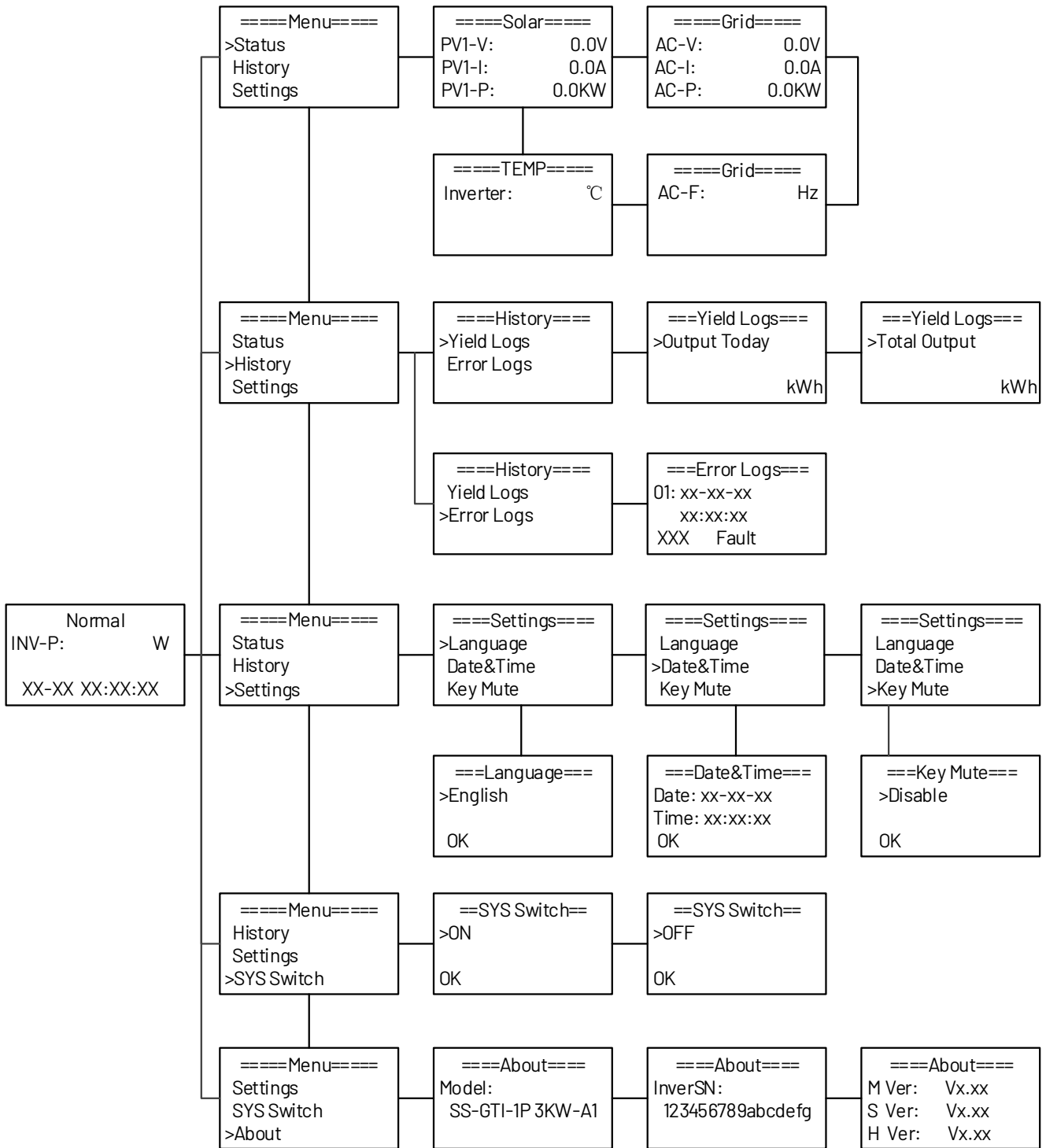

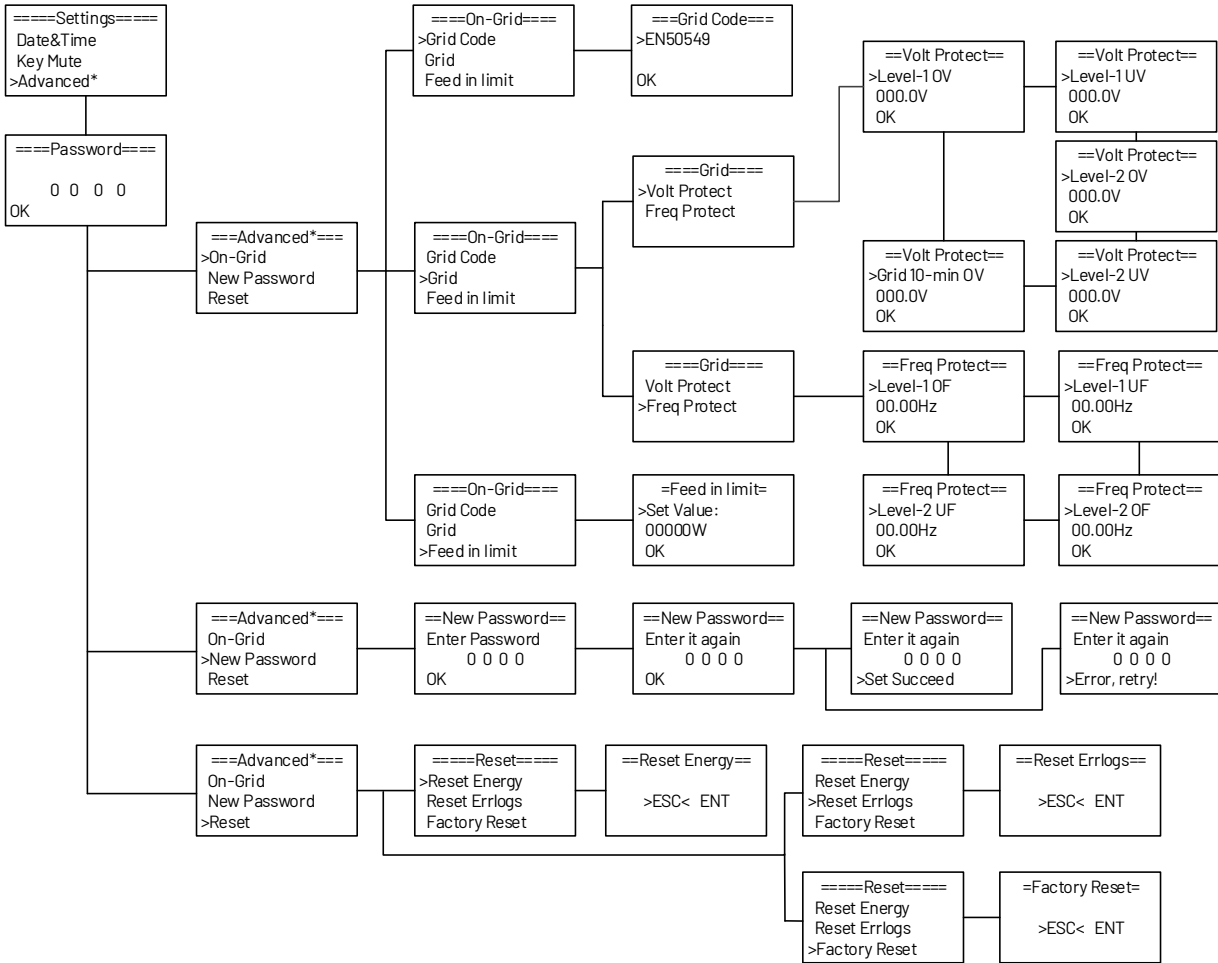

### 4.3 History

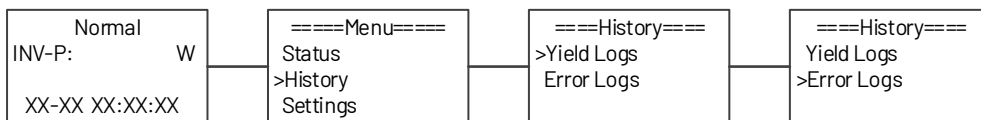

### 4.4 Setting

There are two types of confirmation in the setting function.

1. Press and hold the OK button for 2~3 seconds to confirm the selection. If the setting is successful, 'Set Succeed' will be displayed below; if the setting fails, 'Set Failed' will be displayed below. When 'Setting Successful' or 'Setting Failure' appears below, you can press ESC button to return or press the OK button briefly to re-select. Take setting the language as an example.

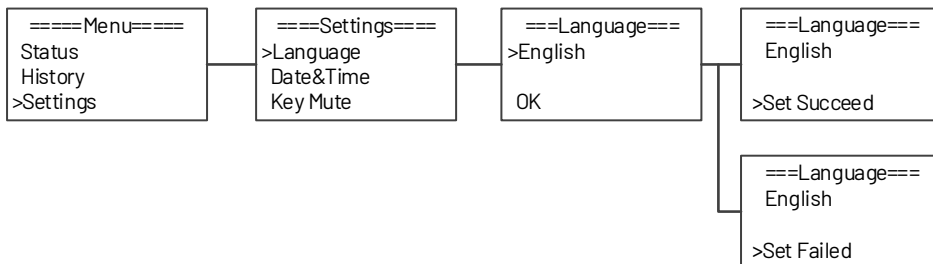

2. Press the OK button briefly to enter the second confirmation interface; users need to select 'ENT' to confirm formally. If the setting is successful, 'Set Succeed' will be displayed below, and the page will automatically return to the previous page in a while; if the

setting fails, 'Set Failed' will be displayed below, and the page will be fixed, and the user will need to press the ESC button to return to the previous page. Take setting the language as an example.

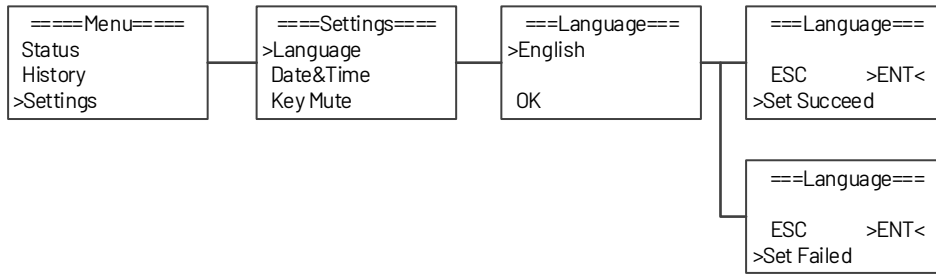

#### 4.4.1 Language

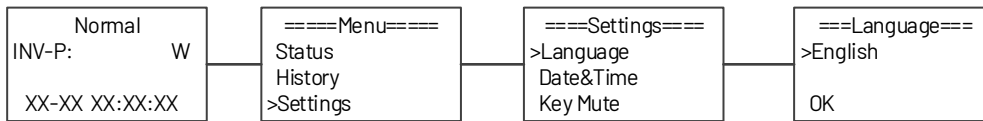

#### 4.4.2 Date and time

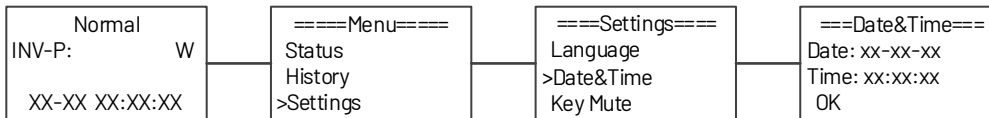

#### 4.4.3 Grid code

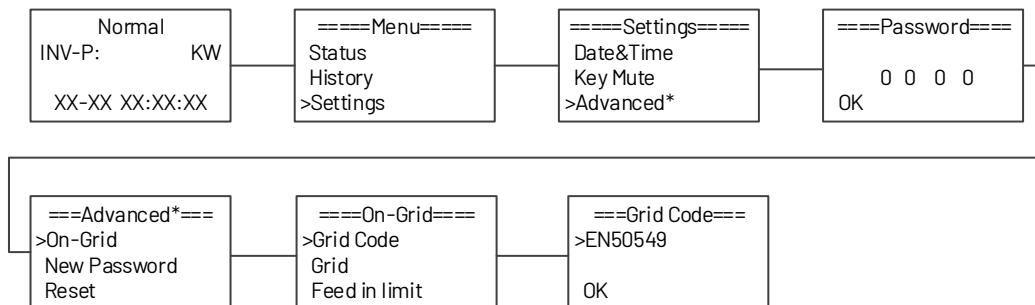

#### 4.4.4 Feed in limit

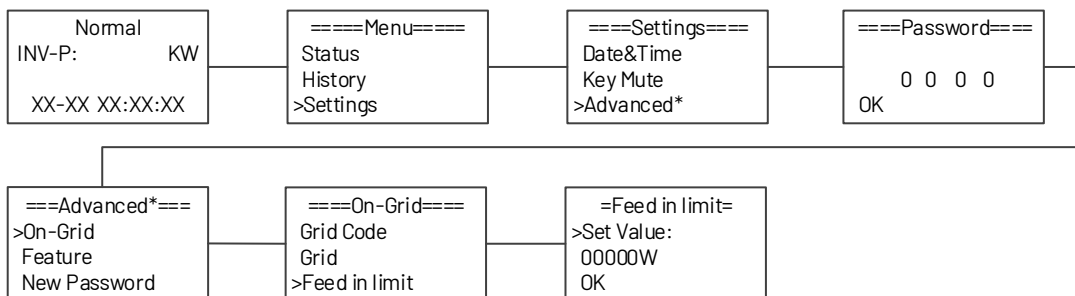

4.4.5 New password

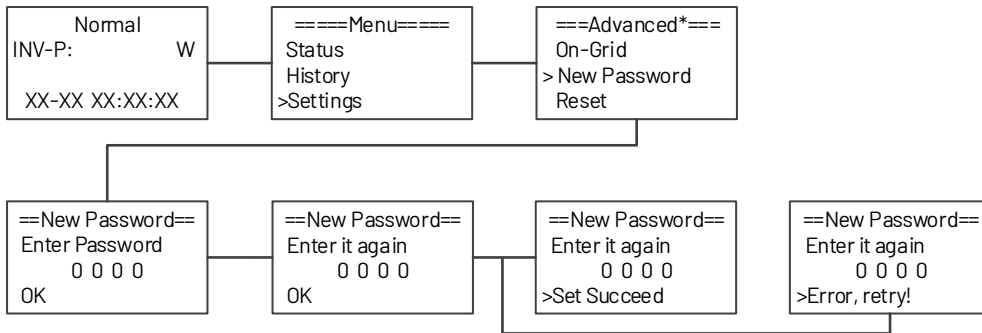

4.4.6 Reset

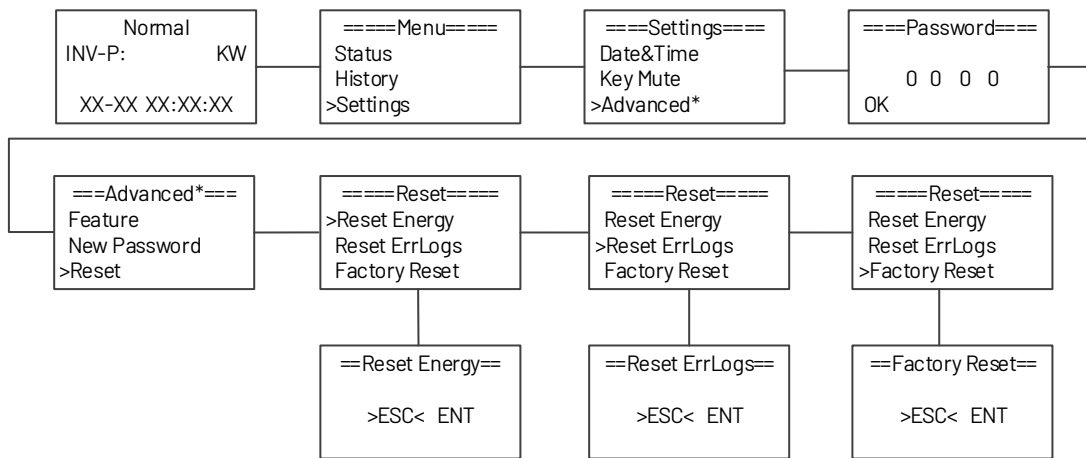

4.5 System switch

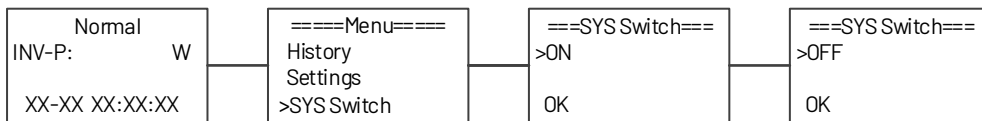

4.6 About

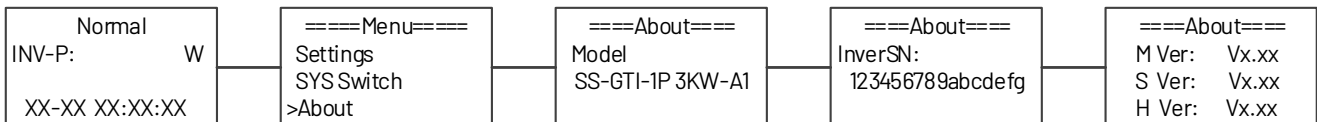

## 5. Warranty

### 5.1 Warranty claim procedure

Please report defective device with a brief error description and SN code to our service mail or service hotline for registration. Alternatively, please contact your specific dealer or installer if your unit is defective or faulty. To claim the warranty under the warranty terms of factory, you need to supply us with the following information and documentation regarding the faulty unit:

- 1) Product Model (e.g.SS-GTI-1P 3KW-A1) and the Serial Number (e.g. 8011A33230801002).
- 2) Copy of the invoice and warranty certificate for the inverter.
- 3) Error message on LCD screen and additional information regarding the fault/error.
- 4) Detailed information about the entire system (modules, circuits, etc.).
- 5) Documentation of previous claim/exchanges (if applicable).

In the case of an exchange, the remainder of the warranty entitlement will be transferred to the replacement device. In this event, you will not receive a new certificate, as this replacement will be noted by factory.

### 5.2 Service after warranty expiration

For products which are out of warranty, factory charges an on-site service fee, parts, labor cost and logistic fee to end-user which can be any/all of:

- 1) On-site attendance fee: Cost of travel and time for the technician in attending on-site;
- 2) Parts: Cost of replacement parts (including any shipping/admin fee that may apply);
- 3) Labor: Labor time fee charged for the technician, who is repairing, maintaining, and installing (hardware or software) and debugging the faulty product;
- 4) Logistic fee: Cost of delivery, tariff and other derived expense when defective products are sent from user to factory or/ and repaired products are sent from factory to user.

## 6. Troubleshooting and maintenance

### 6.1 Troubleshooting

Once a fault occurs in the inverter, the fault information can be displayed on screen or the App interface. Fault codes and check methods are as follows:

No.	LCD display	Possible actions
1	Grid Lost Fault	Grid voltage too low. <ul style="list-style-type: none"> <li>• System will reconnect if the utility is back to normal.</li> <li>• Or seek help from us, if not go back to normal state</li> </ul>
2	Grid Volt Fault	Grid voltage out of range. <ul style="list-style-type: none"> <li>• System will reconnect if the utility is back to normal!</li> <li>• Or seek help from us, if not go back to normal state.</li> </ul>
3	Grid Freq Fault	Grid frequency out of range. <ul style="list-style-type: none"> <li>• System will reconnect if the utility is back to normal.</li> <li>• Or seek help from us, if not go back to normal state.</li> </ul>
4	Vgrid 10M Fault	The grid voltage is out of range for the last 10 Minutes.

No.	LCD display	Possible actions
		<ul style="list-style-type: none"> <li>• System will reconnect if the utility is back to normal.</li> <li>• Or seek help from us, if not go back to normal state</li> </ul>
5	Inv SW OCP Fault	Disconnect PV, and grid, then reconnect. <ul style="list-style-type: none"> <li>• Or seek help from us, if not go back to normal state.</li> </ul>
6	DCI OCP Fault	DC component is out of limit in output current. <ul style="list-style-type: none"> <li>• Disconnect PV, grid and battery, then reconnect.</li> <li>• Or seek help from us, if not go back to normal state.</li> </ul>
7	Inv HW OCP Fault	Disconnect PV, and grid, then reconnect. <ul style="list-style-type: none"> <li>• Or seek help from us, if not go back to normal state.</li> </ul>
8	Bus Volt Fault	Bus voltage out of range detected by software. <ul style="list-style-type: none"> <li>• Disconnect PV and grid, then reconnect.</li> <li>• Or seek help from us, if not go back to normal state.</li> </ul>
9	Iso Check Fault	The isolation is failed. <ul style="list-style-type: none"> <li>• Please check if the insulation of electric wires is damaged.</li> <li>• Wait for a while to check if back to normal.</li> </ul>
10	GFCI Fault	The errors are internal faults of the inverter.
11	PV Curt Fault	<ul style="list-style-type: none"> <li>• Disconnect PV, and grid, then reconnect.</li> <li>• Or seek help from us, if not go back to normal state.</li> </ul>
12	PV Volt Fault	The errors are configuration faults of the PV panels. <ul style="list-style-type: none"> <li>• Check the configuration of PV panels and cable connections.</li> <li>• Or seek help from us, if not go back to normal state.</li> </ul>
13	Temp Fault	The errors are internal faults of the inverter. <ul style="list-style-type: none"> <li>• Disconnect PV and grid, then reconnect.</li> <li>• Or seek help from us, if not go back to normal state.</li> </ul>
14	HW Bus Ovp Fault	
15	HW Pv Ocp Fault	
16	SCI Comm Fault	
17	SPI Comm Fault	
18	Auto test Fault	
19	AD Sample Fault	
20	GFCI HW Fault	
21	Inv EEPROM Fault	
22	Pv NegCurt Fault	
23	Relay Open	The meter connection is lost. <ul style="list-style-type: none"> <li>• Please check if the meter connection is normal.</li> <li>• Or seek help from us.</li> </ul>
24	Relay S1 Short	
25	Relay S2 Short	
26	Relay M1 Short	
27	Relay M2 Short	
28	HMI EEPROM Fault	
29	Meter Lost Fault	

**6.2 Maintenance**

	<p>Risk of inverter damage or personal injury due to incorrect service!</p> <ul style="list-style-type: none"> <li>• Always keep in mind that the inverter is powered by dual sources: PV strings and utility grid. Before any service work, observe the following procedure.</li> <li>• Disconnect the AC circuit breaker and then set the DC load-break switch of the inverter to OFF.</li> <li>• Wait at least 5 minutes for inner capacitors to discharge completely.</li> <li>• Verify that there is no voltage or current before pulling any connector.</li> </ul>
<p><b>NOTICE</b></p>	<p><b>NOTICE!</b></p> <p>Restart the inverter only after removing the fault that impairs safety performance. As the inverter contains no component parts that can be maintained, never arbitrarily replace any internal components. For any maintenance need, please contact manufacturer. Otherwise, manufacturer shall not be held liable for any damage caused.</p>

**6.2.1 Routine Maintenance**

Item	LCD display	Period
System clean	Check the temperature and dust of the inverter. Clean the inverter enclosure if necessary. Check if the air inlet and outlet are normal, Clean the air inlet and outlet if necessary	Six months to a year (- depend on the dust contents in air.)
Cable entry	Check whether the cable entry is insufficiently sealed or the gap is excessively large, and reseal the entry when necessary!	Once a year
Electrical Connection	Check whether all cable are firmly in place. Check whether a cable is damaged, especially the part contacting the metal enclosure.	Six months to a year



